

GUNITE SKIMMER TEST LOOP KIT INSTRUCTIONS

KIT INCLUDES

Part No.	Qty.	Description
715-9920	2	Test Plug - 1 1/2" / 2" MPT Threads
805-0224	2	O-Ring
820-0006	2	Nut
872-2260	1	Tube - 5/16" x 12

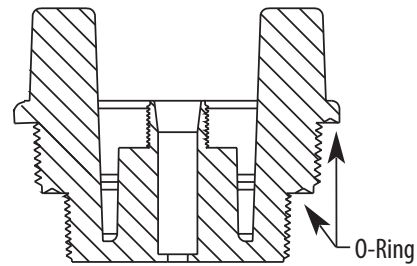

DIAGRAM 1

DIRECTIONS

1. Install o-rings onto either 1 1/2" ridge or 2" depending on what size skimmer you are testing (see Diagram 1). USE SILICONE GREASE FOR BEST RESULTS.
2. Place nuts on plugs until threads engage at least two turns. Insert plugs into skimmer until hand tight. **DO NOT OVER TIGHTEN.** Finish tightening with 1 1/2" pipe slotted at one end (see Diagram 2).
3. Put each end of tubing through each nut (see Diagram 3). Tighten each nut onto each test plug (see Diagram 4).
4. To remove, loosen nut. Take plugs out of skimmer with slotted pipe.
DISPOSABLE OR REUSABLE - YOUR CHOICE!

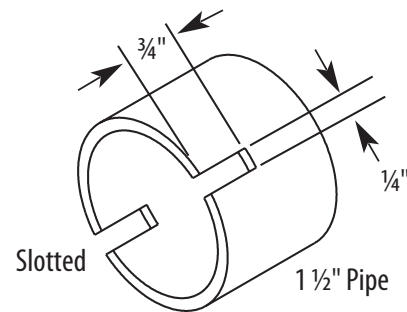

DIAGRAM 2

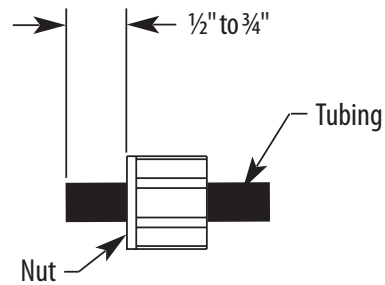

DIAGRAM 3

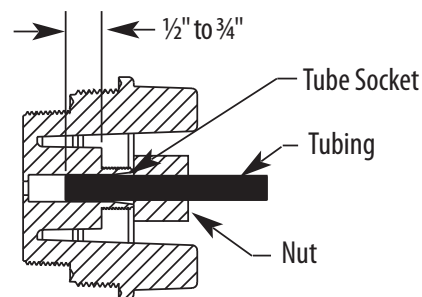

DIAGRAM 4

NOTE: If test plugs are reused, check for any damage. After removal from skimmer, install new o-ring. Replace tubing when necessary.



© 2009 Waterway Plastics

Waterway™

2200 East Sturgis Road, Oxnard, CA 93030 • Ph. (805) 981-0262 • Fax (805) 981-9403
www.waterwayplastics.com • waterway@waterwayplastics.com

810-0050.0109