

# TURBO JET INSTALLATION INSTRUCTIONS

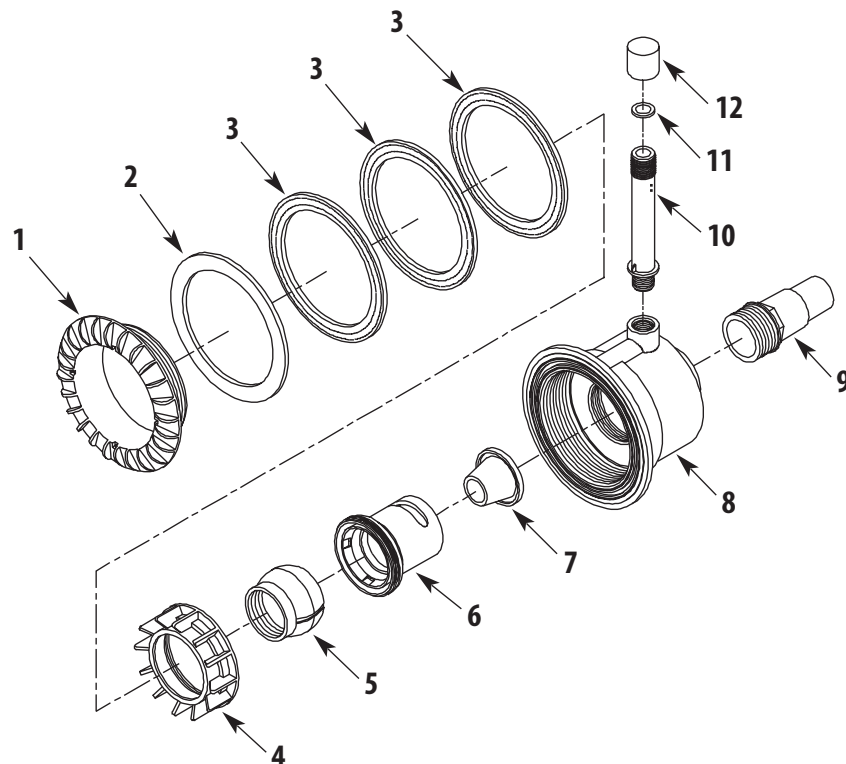
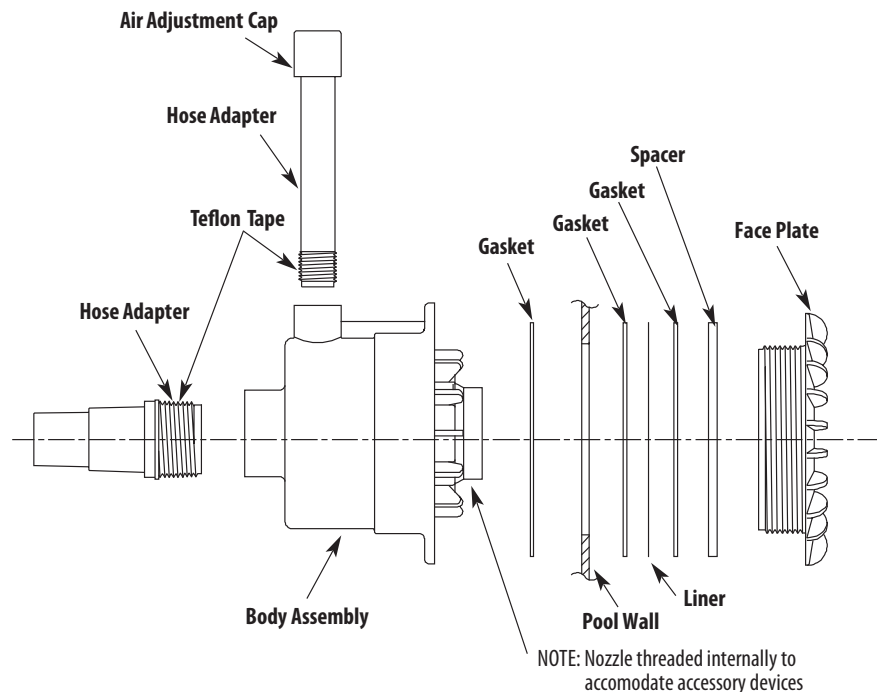

## INSTALLATION AND OPERATION

The Turbo Jet fitting installs through a pre-cut hole in the pool wall.

1. With the vinyl liner in place, gently press the liner to locate the exact wall opening. Make a circular cut out in the vinyl liner  $\frac{1}{2}$ " -  $\frac{3}{4}$ " smaller than the opening in the wall.
2. Place the plastic spacer on the threaded face plate. Place the 1st rubber gasket next to the spacer. Place 2nd rubber gasket between the wall and liner. Hold it in place while inserting threaded face plate from inside of the pool through the cut-out opening.
3. Place a 3rd rubber gasket over the face plate threads from outside of the pool wall.
4. Thread fitting body assembly onto face plate and tighten securely. Make sure air line outlet is located at the top (12 o'clock position).
5. The air and water mixture may be adjusted by turning the top air adjustment cap.
6. Thread hose adapter (with pip tape on threads) into Turbo Boost fitting body. The Turbo Boost Jet inlet substantially increases the regular return water flow creating extra high powered circulation of your pool - with or without an

## TURBO JET REPLACEMENT PARTS

Item	Part No.	Description
1	111940	Wallfitting
2	111947	Plastic Ring
3	111946	Rubber Gasket
4	111937	Top Eyeball Retainer
5	111938	Eyeball
6	111936	Bottom Ball Retainer
7	111935	Water Nozzle
8	111941	Jet Body
9	111747	Combo Fitting
10	111948	Stand Pipe
11	111950	$\frac{3}{4}$ " Gasket
12	111949	Cap for Pipe