



## Pool Filters / TWM-30 Series Systems

### FEATURES:

- 25 sq. ft. cartridge filter
- 1/8 HP energy efficient pump with trap
- 6 ft. NEMA cord
- 30 GPM flow rate
- Two 6 ft. x 1 1/2" hoses with connectors
- Equipment pad



**NEW**

### TWM-30 Above Ground Cartridge Filter System

Part No.	Description	Flow Rate	Turnover (24 hrs.)	Cord	List (US \$)
<b>520-4070</b>	25 sq. ft. Filter - 1/8 HP Pump	1800 GPH	43,200 gals.	6 ft. NEMA	530.55
<b>520-4070LT</b>	25 sq. ft. Filter - 1/8 HP Pump - without Trap	1800 GPH	43,200 gals.	6 ft. NEMA	456.08
<b>400-6700</b>	Intex Fitting Package	--	--	--	17.17

### FEATURES:

- 16in. sand filter
- 1/2 HP energy efficient pump with trap
- 6 ft. NEMA cord
- Two 6 ft. x 1 1/2" hoses with connectors
- Equipment pad



**NEW**

### TWM-30-S Sand Filter System

Part No.	Description	Flow Rate	Turnover (24 hrs.)	Cord	List (US \$)
<b>520-1601</b>	16in. Filter - 1/2 HP Pump	1800 GPH	43,200 gals.	6 ft. NEMA	545.00
<b>520-1601LT</b>	16in. Filter - 1/2 HP Pump - without Trap	1800 GPH	43,200 gals.	6 ft. NEMA	465.40
<b>400-6700</b>	Intex Fitting Package	--	--	--	17.17



**FEATURES:**

- NSF Listed
- 2 ½" internal piping
- 2 ½" Valve Bulkhead Unions (includes 2" and 1 ½" reducers)
- Fiberglass reinforced polypropylene body for superior strength
- "Multi-Handle" design
- Heavy-duty tamper-proof clamp
- Industry-proven D.E. grids
- "Start-Service" dial on stainless steel pressure gauge
- 1 ½" bottom clean-out port
- 2 ½" hi-temp PVC slide valve available
- 2 ½" x 2" Multi-Port Valves – available in Slip or FPT
- Convertible to cartridge by simply changing internals



For replacement parts, see page 237.

*Designed for today's most demanding installations, the Crystal Water D.E. Filter sets a new standard of performance and features for pool filters. The only D.E. filter on the market with 2 ½" internal piping, improves flow and reduces system noise when using 2 ½", 2" or 1 ½" plumbing. From the lid with the "Multi-Handle" design to the 2" bottom clean out port, the Crystal Water D.E. Filter will provide years of trouble-free operation and crystal clear, sparkling water.*

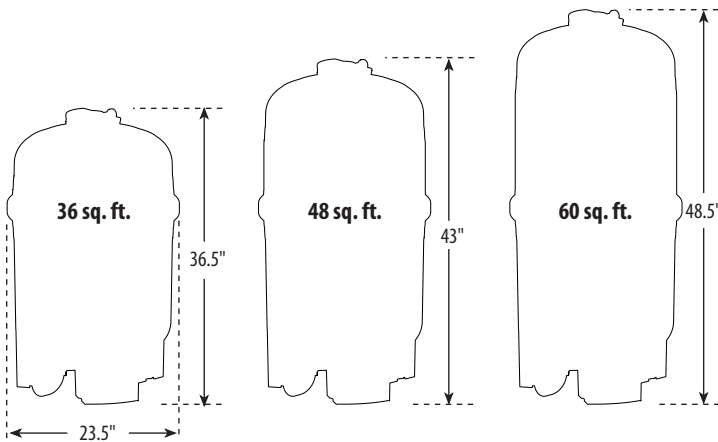

**Crystal Water D.E. Filters**

Part No.	Size	Flow Rate	Pool Turnover (6 hrs.)	Pool Turnover (8 hrs.)	Weight (lbs.)	List (US \$)
<b>570-0036-07</b>	36 sq. ft.	72 GPM	25,920	34,560	70	1191.36
<b>570-0048-07</b>	48 sq. ft.	96 GPM	34,560	46,080	80	1353.92
<b>570-0060-07</b>	60 sq. ft.	120 GPM	43,200	57,600	90	1489.34

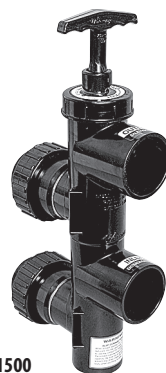

600-1500



WVD001

**Valves for D.E. Filters**

Part No.	Description	Case Quantity	List (US \$)
<b>600-1500</b>	2 ½" Hi-Temp PVC Slide Valve Assembly (2" and 1 ½" reducers included)	1	134.15
<b>550-4280</b>	Slide Valve Adapter Fitting Package for D.E. / Cartridge Filter (2" and 1 ½" reducers included)	1	41.78
<b>WVD001</b>	Multi-Port Valve with Union Connections - 2" FPT	1	217.23
<b>WVD002</b>	Multi-Port Valve with Union Connections - 2" Socket	1	217.23



## Pool Filters - In-Ground / Crystal Water - Cartridge

### FEATURES:

- NSF Listed
- 2 ½" internal piping
- 2 ½" Valve Bulkhead Unions (includes 2" and 1 ½" reducers)
- Fiberglass reinforced polypropylene body for superior strength
- "Multi-Handle" design
- Heavy-duty tamper-proof clamp with removal tool
- Industry proven quad-cartridge elements layout
- "Start-Service" dial on stainless steel pressure gauge
- 1 ½" bottom clean-out port
- Convertible to D.E. by simply changing internals

Combining high technology features and an easy to service design, the Crystal Water Cartridge Filter is ideal for new and replacement installations. The only cartridge filter on the market with 2 ½" internal piping, improves flow and reduces system noise when using 2 ½", 2" or 1 ½" plumbing. Using four cartridge elements, the Crystal Water Cartridge Filter offers a superior choice for easy maintenance and crystal clear, clean water.



Cluster of 4 cartridge elements for ease of maintenance and longer cleaning cycles.



For replacement parts, see page 239.

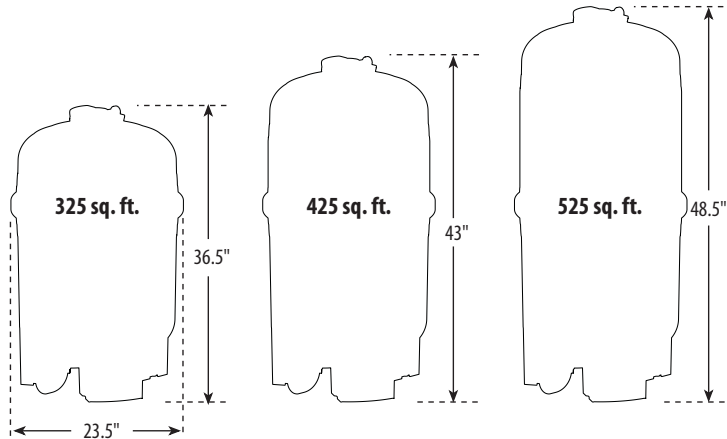

### Crystal Water Cartridge Filters

Part No.	Size	Flow Rate	Pool Turnover (6 hrs.)	Pool Turnover (8 hrs.)	Weight (lbs.)	List (US \$)
<b>570-0325-07</b>	325 sq. ft.	150 GPM	43,200	57,600	70	1502.76
<b>570-0425-07</b>	425 sq. ft.	150 GPM	54,000	72,000	80	1692.44
<b>570-0525-07*</b>	525 sq. ft.	150 GPM	54,000	72,000	90	1963.21

\* Ideal for longer cleaning cycles



**FEATURES:**

- True Spiral Laminar flow for even disbursement of D.E.
- Automatic hydraulic regeneration
- High flow rate
- Modular grid system for easy maintenance
- Union gate valve with 1 1/2" hose adapter drain shut off
- Flush-mounted stainless steel pressure gauge
- Low-profile air relief plug
- Automatic air bleed capability
- Heavy-duty lid handle



*True Spiral Laminar flow in an above ground filter. Spiral Laminar flow ensures even distribution of D.E. for maximum filtration. The ClearWater D.E. filter features automatic hydraulic regeneration, Waterway's Safety Lock Ring system for safe operation and maintenance, and a ten year warranty on its rugged glass-filled polymer body.*

*For replacement parts, see page 241.  
For equipment bases, see page 11.*

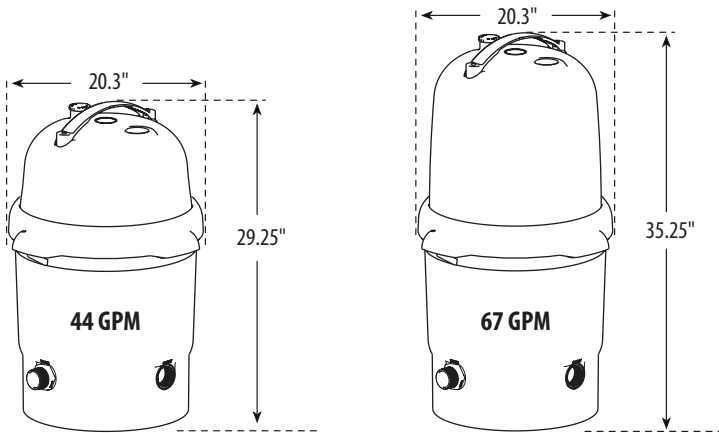

**ClearWater II D.E. Filters**

Part No.	Description	Filtration Area	Pool Turnover (6 hrs.)	Pool Turnover (8 hrs.)	Weight (lbs.)	List (US \$)
<b>FD12-7</b>	44 GPM Filter	12 sq. ft.	15,840	21,120	34	613.35
<b>FD18-7</b>	67 GPM Filter	18 sq. ft.	24,120	32,160	41	738.29

**ClearWater II D.E. Accessories**

Part No.	Description	Case Quantity	List (US \$)
<b>672-7211</b>	ClearWater Modular Filter Base - 7" x 23" Diameter	1	65.05
<b>429-7300</b>	Pin and Anchor Assembly Kit for Base	--	6.78



## Pool Filters - Above Ground / ClearWater II - D.E. Deluxe System

Complete the D.E. filtration system with the high performance Waterway Supreme Pump and accessories. The D.E. Filter and Pump Pack provides homeowners with everything they need to get their system up and running. It assures them of matched components and optimal performance with years of dependable service.

### FEATURES:

- True Spiral Laminar flow D.E. filter
- Top of the line Supreme High Performance Single or Dual Speed Pump
- Extra large 7" pump trap with clear lid
- Unionized gate valve to isolate the system for maintenance
- Drain Shut Off - Union Gate Valve with 1 1/2" hose adapter
- Two 1 1/2" diameter hoses with clamps
- Filter and pump mounting base, complete fitting package for all connections
- Accessory base (optional) allows for addition of optional timer and/or chlorinator kits for minimal maintenance
- Dual speed pump meets CEC Title 20 Code - Effective January 1, 2008



### INCLUDES:

- 2 hoses (1 1/2" x 6 ft.)
- Filter / Pump Union Adapter, Hose fittings and hose clamps
- 3 ft. cord Twist-Lock plug (NEC/UL), or 6 ft. cord NEMA plug
- 2 Unionized gate valve to isolate system for maintenance & drain
- Accessory base for optional timer and/or chlorinator

### ClearWater II D.E. Deluxe Systems - Supreme 2-Speed Pump

Part No.	Filter	Flow Rate	Pump	HP	Volts	Cord	List (US \$)
<b>FDS044107-3</b>	FD12-7	44 GPM	PSP2100-3R	1.0	115	3 ft. Twist-Lock	1236.74
<b>FDS067107-3</b>	FD18-7	67 GPM	PSP2100-3R	1.0	115	3 ft. Twist-Lock	1541.50
<b>FDS067157-3</b>	FD18-7	67 GPM	PSP2150-3R	1.5	115	3 ft. Twist-Lock	1570.96
<b>FDS044107-6</b>	FD12-7	44 GPM	PSP2100-6R	1.0	115	6 ft. NEMA	1236.74
<b>FDS067107-6</b>	FD18-7	67 GPM	PSP2100-6R	1.0	115	6 ft. NEMA	1541.50
<b>FDS067157-6</b>	FD18-7	67 GPM	PSP2150-6R	1.5	115	6 ft. NEMA	1570.96

### INCLUDES:

- 2 hoses (1 1/2" x 6 ft.)
- Filter / Pump Union Adapter, Hose fittings and hose clamps
- 3 ft. cord Twist-Lock plug (NEC/UL), or 6 ft. cord NEMA plug
- 2 Unionized gate valve to isolate system for maintenance & drain
- Accessory base for optional timer and/or chlorinator

### ClearWater II D.E. Deluxe Systems - Supreme 1-Speed Pump

Part No.	Filter	Flow Rate	Pump	HP	Volts	Cord	List (US \$)
<b>FDS044107-3S</b>	FD12-7	44 GPM	PSP1100-3R	1.0	115	3 ft. Twist-Lock	1088.27
<b>FDS067107-3S</b>	FD18-7	67 GPM	PSP1100-3R	1.0	115	3 ft. Twist-Lock	1268.70
<b>FDS067157-3S</b>	FD18-7	67 GPM	PSP1150-3R	1.5	115	3 ft. Twist-Lock	1592.60
<b>FDS044107-6S</b>	FD12-7	44 GPM	PSP1100-6R	1.0	115	6 ft. NEMA	1088.27
<b>FDS067107-6S</b>	FD18-7	67 GPM	PSP1100-6R	1.0	115	6 ft. NEMA	1268.70
<b>FDS067157-6S</b>	FD18-7	67 GPM	PSP1150-6R	1.5	115	6 ft. NEMA	1592.60

### INCLUDES:

- 2 hoses (1 1/2" x 6 ft.)
- Filter / Pump Union Adapter, Hose fittings and hose clamps
- 2 Unionized gate valve to isolate system for maintenance & drain
- Accessory base for optional timer and/or chlorinator

### ClearWater II D.E. Deluxe Systems (without Supreme Pump)

Part No.	Filter	Flow Rate	List (US \$)
<b>FDS0447S</b>	FD12-7	44 GPM	723.97
<b>FDS0677S</b>	FD18-7	67 GPM	1029.73



**FEATURES:**

- True Spiral Laminar flow D.E. filter
- Hi-Flo High Performance Single or Dual Speed Pump
- Large 6" pump trap with one-piece clear lid
- Two 1 1/2" diameter hoses with clamps
- Complete fitting package for all connections
- Dual Speed meets CEC Title 20 Code - Effective January 1, 2008



*The D.E. Filter and Pump Pack provides homeowners with everything they need to get their system up and running. It assures them of matched components and optimal performance with years of dependable service.*

**ClearWater II D.E. Standard Systems - Hi-Flo 2-Speed Pump**

Part No.	Filter	Flow Rate	Pump	HP	Volts	Cord	List (US \$)
<b>522-5007-3S</b>	FD12-7	44 GPM	PH2100-3R	1.0	115	3 ft. Twist-Lock	1051.38
<b>522-5027-3S</b>	FD18-7	67 GPM	PH2100-3R	1.0	115	3 ft. Twist-Lock	1208.41
<b>522-5037-3S</b>	FD18-7	67 GPM	PH2150-3R	1.5	115	3 ft. Twist-Lock	1250.82
<b>522-5007-6S</b>	FD12-7	44 GPM	PH2100-6R	1.0	115	6 ft. NEMA	1051.38
<b>522-5027-6S</b>	FD18-7	67 GPM	PH2100-6R	1.0	115	6 ft. NEMA	1208.41
<b>522-5037-6S</b>	FD18-7	67 GPM	PH2150-6R	1.5	115	6 ft. NEMA	1250.82

**INCLUDES:**

- 2 Hoses (1 1/2" x 6 ft.)
- Filter/ Pump Union Adapter, Hose fittings and hose clamps
- 3 ft. cord Twist-Lock plug (NEC/UL), or 6 ft. cord NEMA plug
- Standard system base

**ClearWater II D.E. Standard Systems - Hi-Flo 1-Speed Pump**

Part No.	Filter	Flow Rate	Pump	HP	Volts	Cord	List (US \$)
<b>520-5007-3S</b>	FD12-7	44 GPM	PH1100-3R	1.0	115	3 ft. Twist-Lock	990.41
<b>520-5027-3S</b>	FD18-7	67 GPM	PH1100-3R	1.0	115	3 ft. Twist-Lock	1147.43
<b>520-5037-3S</b>	FD18-7	67 GPM	PH1150-3R	1.5	115	3 ft. Twist-Lock	1186.52
<b>520-5007-6S</b>	FD12-7	44 GPM	PH1100-6R	1.0	115	6 ft. NEMA	990.41
<b>520-5027-6S</b>	FD18-7	67 GPM	PH1100-6R	1.0	115	6 ft. NEMA	1147.43
<b>520-5037-6S</b>	FD18-7	67 GPM	PH1150-6R	1.5	115	6 ft. NEMA	1186.52

**INCLUDES:**

- 2 Hoses (1 1/2" x 6 ft.)
- Filter/ Pump Union Adapter, Hose fittings and hose clamps
- 3 ft. cord Twist-Lock plug (NEC/UL), or 6 ft. cord NEMA plug
- Standard system base

**ClearWater II D.E. Standard Systems (without Hi-Flo Pump)**

Part No.	Filter	Flow Rate	List (US \$)
<b>520-5007</b>	FD12-7	44 GPM	698.03
<b>520-5027</b>	FD18-7	67 GPM	721.32

**INCLUDES:**

- 2 Hoses (1 1/2" x 6 ft.)
- Filter/ Pump Union Adapter, Hose fittings and hose clamps
- Standard system base



## Pool Filters - Above Ground / ClearWater II - Cartridge

### FEATURES:

- Wide-body filtration system
- Durable glass-filled polymer filter body
- 10-year warranty on filter body
- 1 ½" clean out drain on 1 ½" FPT
- Flush-mounted stainless steel pressure gauge
- Low-profile air relief plug
- Heavy-duty lid handle

Large filtration, small footprint, and high flow. ClearWater II Cartridge Filters incorporate wide-body filtration elements to give maximum filtration without sacrificing flow rate. Made of a durable glass-filled polymer, ClearWater II Cartridge Filters provide years of trouble-free performance. ClearWater II Cartridge Filters feature Waterway's Safety Lock Ring system to ensure safe operation and easy maintenance.

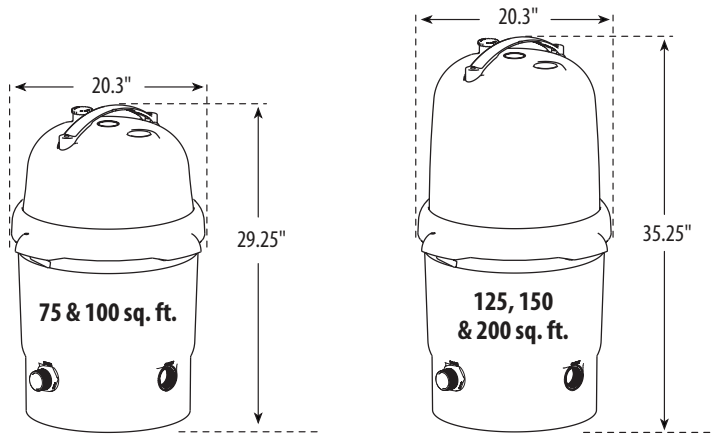

For replacement parts, see page 242.  
For equipment bases, see page 11.

### ClearWater II Cartridge Filters

Part No.	Filtration Area	Flow Rate	Pool Turnover (6 hrs.)	Pool Turnover (8 hrs.)	Weight (lbs.)	List (US \$)
<b>FC0757</b>	75 sq. ft.	75 GPM	27,000	36,000	31	537.22
<b>FC1007</b>	100 sq. ft.	100 GPM	36,000	48,000	36	689.47
<b>FC1257</b>	125 sq. ft.	125 GPM	45,000	60,000	37	739.13
<b>FC1507</b>	150 sq. ft.	150 GPM	54,000	72,000	44	927.92
<b>FC2007*</b>	200 sq. ft.	150 GPM	54,000	72,000	46	1048.57

\*Longer period between cleaning cycles



## FEATURES:

- Large filtration, small footprint cartridge filter
- Top of the line Supreme High Performance Single or Dual Speed Pump
- Extra large 7" pump trap with clear lid
- Unionized gate valve to isolate the system for maintenance
- Two 1 1/2" diameter hoses with clamps
- Filter and pump mounting base
- Complete fitting package for all connections
- Accessory base allows for addition of optional timer and/or chlorinator kits for minimal maintenance
- Dual speed pump meets CEC Title 20 Code - Effective January 1, 2008



Complete the Cartridge filtration system with the Waterway Supreme High Performance Pump and accessories. The Cartridge Filter and Pump Pack provides homeowners with everything they need to get their system up and running. It assures them of matched components and optimal performance with years of dependable service.

## ClearWater II Cartridge Deluxe System with Supreme 2-Speed Pump

Part No.	Filter	Filtration Area	Pump	HP	Volts	Cord	List (US \$)
<b>FCS075107-3</b>	FC0757	75 sq. ft.	PSP2100-3R	1.0	115	3 ft. Twist-Lock	1091.65
<b>FCS100107-3</b>	FC1007	100 sq. ft.	PSP2100-3R	1.0	115	3 ft. Twist-Lock	1301.55
<b>FCS125157-3</b>	FC1257	125 sq. ft.	PSP2150-3R	1.5	115	3 ft. Twist-Lock	1423.33
<b>FCS150157-3</b>	FC1507	150 sq. ft.	PSP2150-3R	1.5	115	3 ft. Twist-Lock	1531.22
<b>FCS200157-3</b>	FC2007	200 sq. ft.	PSP2150-3R	1.5	115	3 ft. Twist-Lock	1561.09
<b>FCS075107-6</b>	FC0757	75 sq. ft.	PSP2100-6R	1.0	115	6 ft. NEMA	1091.65
<b>FCS100107-6</b>	FC1007	100 sq. ft.	PSP2100-6R	1.0	115	6 ft. NEMA	1301.55
<b>FCS125157-6</b>	FC1257	125 sq. ft.	PSP2150-6R	1.5	115	6 ft. NEMA	1423.33
<b>FCS150157-6</b>	FC1507	150 sq. ft.	PSP2150-6R	1.5	115	6 ft. NEMA	1531.22
<b>FCS200157-6</b>	FC2007	200 sq. ft.	PSP2150-6R	1.5	115	6 ft. NEMA	1561.09

## INCLUDES:

- 2 hoses (1 1/2" x 6 ft.)
- Filter / Pump Union Adapter, Hose fittings and hose clamps
- 3 ft. cord Twist-Lock plug (NEC/UL), or 6 ft. cord NEMA plug
- Deluxe one-piece base system
- Unionized gate valve to isolate system for maintenance
- Accessory base for optional timer and/or chlorinator

## ClearWater II Cartridge Deluxe System with Supreme 1-Speed Pump

Part No.	Filter	Filtration Area	Pump	HP	Volts	Cord	List (US \$)
<b>FCS075107-3S</b>	FC0757	75 sq. ft.	PSP1100-3R	1.0	115	3 ft. Twist-Lock	971.72
<b>FCS100107-3S</b>	FC1007	100 sq. ft.	PSP1100-3R	1.0	115	3 ft. Twist-Lock	1107.19
<b>FCS125157-3S</b>	FC1257	125 sq. ft.	PSP1150-3R	1.5	115	3 ft. Twist-Lock	1215.09
<b>FCS150157-3S</b>	FC1507	150 sq. ft.	PSP1150-3R	1.5	115	3 ft. Twist-Lock	1295.63
<b>FCS200157-3S</b>	FC2007	200 sq. ft.	PSP1150-3R	1.5	115	3 ft. Twist-Lock	1419.31
<b>FCS075107-6S</b>	FC0757	75 sq. ft.	PSP1100-6R	1.0	115	6 ft. NEMA	971.72
<b>FCS100107-6S</b>	FC1007	100 sq. ft.	PSP1100-6R	1.0	115	6 ft. NEMA	1107.19
<b>FCS100137-6S</b>	FC1007	100 sq. ft.	PSP1075-6R	0.75	115	6 ft. NEMA	1030.76
<b>FCS125157-6S</b>	FC1257	125 sq. ft.	PSP1150-6R	1.5	115	6 ft. NEMA	1215.09
<b>FCS150157-6S</b>	FC1507	150 sq. ft.	PSP1150-6R	1.5	115	6 ft. NEMA	1295.63
<b>FCS200137-6S</b>	FC2007	200 sq. ft.	PSP1075-6R	0.75	115	6 ft. NEMA	1088.28
<b>FCS200157-6S</b>	FC2007	200 sq. ft.	PSP1150-6R	1.5	115	6 ft. NEMA	1419.31

## INCLUDES:

- 2 hoses (1 1/2" x 6 ft.)
- Filter / Pump Union Adapter, Hose fittings and hose clamps
- 3 ft. cord Twist-Lock plug (NEC/UL), or 6 ft. cord NEMA plug
- Deluxe one-piece base system
- Unionized gate valve to isolate system for maintenance
- Accessory base for optional timer and/or chlorinator

## ClearWater II Cartridge Deluxe System (without Supreme Pump)

Part No.	Filter	Filtration Area	List (US \$)
<b>FCS0757S</b>	FC0757	75 sq. ft.	605.62
<b>FCS1007S</b>	FC1007	100 sq. ft.	640.15
<b>FCS1257S</b>	FC1257	125 sq. ft.	675.38
<b>FCS1507S</b>	FC1507	150 sq. ft.	710.48
<b>FCS2007S</b>	FC2007	200 sq. ft.	747.27

## INCLUDES:

- 2 hoses (1 1/2" x 6 ft.)
- Filter/ Pump Union Adapter, Hose fittings and hose clamps
- Deluxe one-piece base system
- Unionized gate valve to isolate system for maintenance
- Accessory base for optional timer and/or chlorinator





## Pool Filters - Above Ground / ClearWater II - Cartridge Standard System

### FEATURES:

- Large filtration, small footprint cartridge filter
- Hi-Flo High Performance Single or Dual Speed Pump
- Large 6" pump trap with one-piece clear lid
- Two 1 1/2" diameter hoses, with clamps
- Dual speed pump meets CEC Title 20 Code - Effective January 1, 2008

The Cartridge Filter and Pump Pack provides homeowners with everything they need to get their system up and running. It assures them of matched components and optimal performance with years of dependable service.



### INCLUDES:

- 2 hoses (1 1/2" x 6 ft.)
- Filter/ Pump Union Adapter, Hose fittings and hose clamps
- 3 ft. cord Twist-Lock plug (NEC/UL), or 6 ft. cord NEMA plug
- One-piece system base

### ClearWater II Cartridge Standard System with Hi-Flo 2-Speed Pump

Part No.	Filter	Filtration Area	Pump	HP	Volts	Cord	List (US \$)
<b>522-5107-3S</b>	FC0757	75 sq. ft.	PH2100-3R	1.0	115	3 ft. Twist-Lock	942.90
<b>522-5127-3S</b>	FC1007	100 sq. ft.	PH2100-3R	1.0	115	3 ft. Twist-Lock	1087.08
<b>522-5147-3S</b>	FC1007	100 sq. ft.	PH2150-3R	1.5	115	3 ft. Twist-Lock	1096.68
<b>522-5157-3S</b>	FC1257	125 sq. ft.	PH2150-3R	1.5	115	3 ft. Twist-Lock	1167.97
<b>522-5167-3S</b>	FC1507	150 sq. ft.	PH2150-3R	1.5	115	3 ft. Twist-Lock	1239.27
<b>522-5187-3S</b>	FC2007	200 sq. ft.	PH2150-3R	1.5	115	3 ft. Twist-Lock	1328.37
<b>522-5107-6S</b>	FC0757	75 sq. ft.	PH2100-6R	1.0	115	6 ft. NEMA	942.90
<b>522-5127-6S</b>	FC1007	100 sq. ft.	PH2100-6R	1.0	115	6 ft. NEMA	1087.08
<b>522-5147-6S</b>	FC1007	100 sq. ft.	PH2150-6R	1.5	115	6 ft. NEMA	1096.68
<b>522-5157-6S</b>	FC1257	125 sq. ft.	PH2150-6R	1.5	115	6 ft. NEMA	1167.97
<b>522-5167-6S</b>	FC1507	150 sq. ft.	PH2150-6R	1.5	115	6 ft. NEMA	1239.27
<b>522-5187-6S</b>	FC2007	200 sq. ft.	PH2150-6R	1.5	115	6 ft. NEMA	1328.36

### INCLUDES:

- 2 hoses (1 1/2" x 6 ft.)
- Filter/ Pump Union Adapter, Hose fittings and hose clamps
- 3 ft. cord Twist-Lock plug (NEC/UL), or 6 ft. cord NEMA plug
- One-piece system base

### ClearWater II Cartridge Standard System with Hi-Flo 1-Speed Pump

Part No.	Filter	Filtration Area	Pump	HP	Volts	Cord	List (US \$)
<b>520-5107-3S</b>	FC0757	75 sq. ft.	PH1100-3R	1.0	115	3 ft. Twist-Lock	881.94
<b>520-5127-3S</b>	FC1007	100 sq. ft.	PH1100-3R	1.0	115	3 ft. Twist-Lock	1026.12
<b>520-5147-3S</b>	FC1007	100 sq. ft.	PH1150-3R	1.5	115	3 ft. Twist-Lock	1032.38
<b>520-5157-3S</b>	FC1257	125 sq. ft.	PH1150-3R	1.5	115	3 ft. Twist-Lock	1103.68
<b>520-5167-3S</b>	FC1507	150 sq. ft.	PH1150-3R	1.5	115	3 ft. Twist-Lock	1174.96
<b>520-5187-3S</b>	FC2007	200 sq. ft.	PH1150-3R	1.5	115	3 ft. Twist-Lock	1288.84
<b>520-5107-6S</b>	FC0757	75 sq. ft.	PH1100-6R	1.0	115	6 ft. NEMA	881.94
<b>520-5127-6S</b>	FC1007	100 sq. ft.	PH1100-6R	1.0	115	6 ft. NEMA	1026.12
<b>520-5147-6S</b>	FC1007	100 sq. ft.	PH1150-6R	1.5	115	6 ft. NEMA	1032.38
<b>520-5157-6S</b>	FC1257	125 sq. ft.	PH1150-6R	1.5	115	6 ft. NEMA	1035.17
<b>520-5167-6S</b>	FC1507	150 sq. ft.	PH1150-6R	1.5	115	6 ft. NEMA	1174.96
<b>520-5187-6S</b>	FC2007	200 sq. ft.	PH1150-6R	1.5	115	6 ft. NEMA	1288.84

### INCLUDES:

- 2 hoses (1 1/2" x 6 ft.)
- Filter/ Pump Union Adapter, Hose fittings and hose clamps
- One-piece system base

### ClearWater II Cartridge Standard System (without Hi-Flo Pump)

Part No.	Filter	Filtration Area	List (US \$)
<b>520-5107</b>	FC0757	75 sq. ft.	348.58
<b>520-5127</b>	FC1007	100 sq. ft.	683.45
<b>520-5a157</b>	FC1257	125 sq. ft.	802.67
<b>520-5167</b>	FC1507	150 sq. ft.	920.20
<b>520-5187</b>	FC2007	200 sq. ft.	1017.56



**FEATURES:**

- NSF Listed
- 2" FPT inlet and outlet for more flow
- Raised inlet for clean easy plumbing and extra dirt holding capacity
- Waterway's Safety Lock Ring System for fast, easy access to filter internals
- Lid lock-ring handle makes removing the lid easy and safe
- Internal design for more dirt holding capacity for longer cleaning cycles
- Drain plug is 3/4", can install a standard 3/4" hose valve for draining
- "Start-Service" dial on stainless steel pressure gauge



Easy access in-ground cartridge internals

Raised 18" Inlet for clean 90° plumbing from pump

Lock-Ring has handles for easy removal of lid



For replacement parts, see page 247.  
For equipment bases, see page 11.

Designed for in-ground installations, the Pro-Clean Cartridge Filter has a raised inlet for extra dirt holding capacity and clean easy plumbing from the pump. Molded of ABS thermoplastic, the Pro-Clean Cartridge Filter will provide years of dependable service.

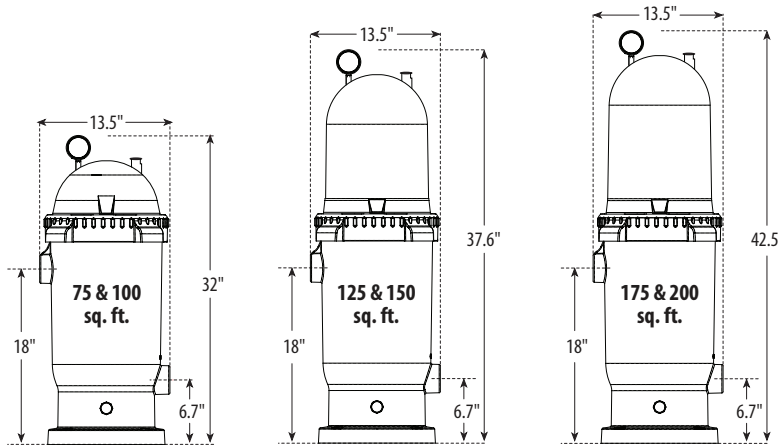

**Pro-Clean Single Cartridge Filters**

Part No.	Size	Flow Rate	Pool Turnover (6 hrs.)	Pool Turnover (8 hrs.)	Weight (lbs.)	List (US \$)
<b>PCCF-075</b>	75 sq. ft.	75 GPM	27,000	36,000	70	480.21
<b>PCCF-100</b>	100 sq. ft.	100 GPM	36,000	48,000	70	577.61
<b>PCCF-125</b>	125 sq. ft.	125 GPM	45,000	60,000	70	706.98
<b>PCCF-150</b>	150 sq. ft.	125 GPM	45,000	60,000	70	820.37
<b>PCCF-175</b>	175 sq. ft.	125 GPM	45,000	60,000	70	921.32
<b>PCCF-200*</b>	200 sq. ft.	125 GPM	45,000	60,000	70	1019.70

\*Ideal for longer cleaning cycles

**Pro-Clean D.E. Cartridge Filters**

Part No.	Description	Flow Rate	Pool Turnover (6 hrs.)	Pool Turnover (8 hrs.)	Weight (lbs.)	List (US \$)
<b>PCDE-30</b>	30 sq. ft. D.E. Cartridge Filter	60 GPM	21,600	28,800	--	820.37
<b>PCDE-40</b>	40 sq. ft. D.E. Cartridge Filter	80 GPM	28,800	38,400	--	1019.70

The cleaning results of a D.E. with the convenience of a cartridge.



# ProPack

**FEATURES:**

- 200 sq. ft. cartridge filter with drain plug or 40 sq. ft. D.E. Element Filter with drain plug
- Champion Pump - Single and Dual Speed Available (not included)
- Equipment pad
- Dual speed pump meets CEC Title 20 Code - Effective January 1, 2008



**Add a Champion Pump to complete your ProPack!**



### Pro-Clean Single Cartridge Filter System - ProPack (without Champion Pump)

Part No.	Description	List (US \$)
<b>520-7500-0</b>	200 sq. ft. Single Cartridge System with Base and Fittings Package	1193.20

### Pro-Clean D.E. Cartridge Filter System - ProPack (without Champion Pump)

Part No.	Description	List (US \$)
<b>520-7820-0</b>	40 sq. ft. D.E. Cartridge System with Base and Fittings Package	1193.20

**Use with Champion Pumps: DO NOT exceed 2 HP for 200 sq ft. Single Cartridge Filter and 1 HP for 40 sq ft. D.E. Filter. See page 6 for Champion Pump choices.**



## FEATURES:

- Raised inlet for clean easy plumbing and extra dirt holding capacity
- Top-mounted pressure gauge for easy reading
- “Start-Service” dial on stainless steel pressure gauge to inform user when it is time to service
- Extra-large air relief
- Drain accepts a standard hose for easy drainage
- Dual speed pump meets CEC Title 20 Code - Effective January 1, 2008



*This system is our Pro-Clean in-ground pool filter with Waterway's above ground Hi-Flo or Supreme Pump for an exceptional above ground system.*

## Pro-Clean Single Cartridge Systems - Hi-Flo Pump -2-Speed

Part No.	Filter	Filtration Area	Pump	HP	List (US \$)
<b>522-6000-6S</b>	PCCF-075	75 sq. ft.	PH2100-6	1.0	960.05
<b>522-6100-6S</b>	PCCF-100	100 sq. ft.	PH2100-6	1.0	1085.39
<b>522-6115-6S</b>	PCCF-100	100 sq. ft.	PH2150-6	1.5	1263.10
<b>522-6215-6S</b>	PCCF-125	125 sq. ft.	PH2150-6	1.5	1320.31
<b>522-6315-6S</b>	PCCF-150	150 sq. ft.	PH2150-6	1.5	1377.50
<b>522-6415-6S</b>	PCCF-175	175 sq. ft.	PH2150-6	1.5	1521.96
<b>522-6515-6S</b>	PCCF-200	200 sq. ft.	PH2150-6	1.5	1638.57
<b>522-6520-6S</b>	PCCF-200	200 sq. ft.	PH2200-6	2.0	1724.34

## Pro-Clean Single Cartridge Systems - Supreme Pump - 2-Speed

Part No.	Filter	Filtration Area	Pump	HP	List (US \$)
<b>FPS07510-6</b>	PCCF-075	75 sq. ft.	PSP2100-6	1.0	1050.65
<b>FPS10010-6</b>	PCCF-100	100 sq. ft.	PSP2100-6	1.0	1188.63
<b>FPS10015-6</b>	PCCF-100	100 sq. ft.	PSP2150-6	1.5	1359.46
<b>FPS12515-6</b>	PCCF-125	125 sq. ft.	PSP2150-6	1.5	1421.28
<b>FPS15015-6</b>	PCCF-150	150 sq. ft.	PSP2150-6	1.5	1483.07
<b>FPS17515-6</b>	PCCF-175	175 sq. ft.	PSP2150-6	1.5	1688.30
<b>FPS20015-6</b>	PCCF-200	200 sq. ft.	PSP2150-6	1.5	1765.12
<b>FPS20020-6</b>	PCCF-200	200 sq. ft.	PSP2200-6	2.0	1857.22



## Pool Filters - Above Ground / ProClean Single Cartridge 1-Speed System

### FEATURES:

- Raised inlet for clean easy plumbing and extra dirt holding capacity
- Top-mounted pressure gauge for easy reading
- "Start-Service" dial on stainless steel pressure gauge to inform user when it is time to service
- Extra-large air relief
- Drain accepts a standard hose for easy drainage

*This system is our Pro-Clean in-ground pool filter with Waterway's above ground Hi-Flo or Supreme Pump for an exceptional above ground system.*



### Pro-Clean Single Cartridge System with Hi-Flo Pump

Part No.	Filter	Filtration Area	Pump	HP	List (US \$)
<b>520-6000-6S</b>	PCCF-075	75 sq. ft.	PH1100-6	1.0	899.09
<b>520-6100-6S</b>	PCCF-100	100 sq. ft.	PH1100-6	1.0	1024.42
<b>520-6115-6S</b>	PCCF-100	100 sq. ft.	PH1150-6	1.5	1198.80
<b>520-6215-6S</b>	PCCF-125	125 sq. ft.	PH1150-6	1.5	1256.00
<b>520-6315-6S</b>	PCCF-150	150 sq. ft.	PH1150-6	1.5	1313.20
<b>520-6415-6S</b>	PCCF-175	175 sq. ft.	PH1150-6	1.5	1457.67
<b>520-6515-6S</b>	PCCF-200	200 sq. ft.	PH1150-6	1.5	1574.27
<b>520-6520-6S</b>	PCCF-200	200 sq. ft.	PH1200-6	2.0	1653.00

### Pro-Clean Single Cartridge System with Supreme Pump

Part No.	Filter	Filtration Area	Pump	HP	List (US \$)
<b>FPS07510-6S</b>	PCCF-075	75 sq. ft.	PSP1100-6	1.0	989.69
<b>FPS10010-6S</b>	PCCF-100	100 sq. ft.	PSP1100-6	1.0	1127.64
<b>FPS10015-6S</b>	PCCF-100	100 sq. ft.	PSP1150-6	1.5	1295.16
<b>FPS12515-6S</b>	PCCF-125	125 sq. ft.	PSP1150-6	1.5	1356.97
<b>FPS15015-6S</b>	PCCF-150	150 sq. ft.	PSP1150-6	1.5	1418.77
<b>FPS17515-6S</b>	PCCF-175	175 sq. ft.	PSP1150-6	1.5	1574.83
<b>FPS20015-6S</b>	PCCF-200	200 sq. ft.	PSP1150-6	1.5	1700.83
<b>FPS20020-6S</b>	PCCF-200	200 sq. ft.	PSP1200-6	2.0	1785.88



**FEATURES:**

- 25, 50 or 100 sq. ft. cartridge filter with drain plug
- Center discharge pool pump - Single and Dual Speed
- 6 ft. NEMA (3-prong, grounded) cord, or 3 ft. Twist-Lock cord
- Two 6 ft. x 1 1/2" hoses with connectors
- Equipment pad
- Optional trap: 1 1/2" Union Nut, 1 1/2" FPT
- Dual speed pump meets CEC Title 20 Code - Effective January 1, 2008



*The economical solution for filtering an above ground pool. Waterway's TWM (Total Water Management) package includes the pump, filter, hoses, and equipment pad.*



For replacement parts, see page 248.

## TWM Cartridge Filter Equipment Packages

Part No.	Description	HP	Volts	Weight (lbs.)	Cord	List (US \$)
<b>522-3040</b>	25 sq. ft. Filter - 2-Speed Pump	1.0	115	34	6 ft. NEMA	610.10
<b>522-3010</b>	50 sq. ft. Filter - 2-Speed Pump	1.0	115	34	6 ft. NEMA	639.60
<b>522-3030</b>	100 sq. ft. Filter - 2-Speed Pump	1.0	115	37	6 ft. NEMA	675.10
<b>522-4040</b>	25 sq. ft. Filter - 2-Speed Pump with Trap	1.0	115	36	6 ft. NEMA	734.70
<b>522-4010</b>	50 sq. ft. Filter - 2-Speed Pump with Trap	1.0	115	36	6 ft. NEMA	764.20
<b>522-4030</b>	100 sq. ft. Filter - 2-Speed Pump with Trap	1.0	115	39	6 ft. NEMA	799.70
<b>522-2980</b>	25 sq. ft. Filter - 2-Speed Pump	1.0	115	34	3 ft. Twist-Lock	610.10
<b>522-4020</b>	50 sq. ft. Filter - 2-Speed Pump with Trap	1.5	115	36	3 ft. Twist-Lock	639.60
<b>520-3040</b>	25 sq. ft. Filter - 1-Speed Pump	1.0	115	34	6 ft. NEMA	565.10
<b>520-3010</b>	50 sq. ft. Filter - 1-Speed Pump	1.0	115	34	6 ft. NEMA	574.64
<b>520-3030</b>	100 sq. ft. Filter - 1-Speed Pump	1.0	115	37	6 ft. NEMA	629.26
<b>520-4040</b>	25 sq. ft. Filter - 1-Speed Pump with Trap	1.0	115	36	6 ft. NEMA	640.10
<b>520-4010</b>	50 sq. ft. Filter - 1-Speed Pump with Trap	1.0	115	36	6 ft. NEMA	669.64
<b>520-4030</b>	100 sq. ft. Filter - 1-Speed Pump with Trap	1.0	115	39	6 ft. NEMA	704.26
<b>520-2a980</b>	25 sq. ft. Filter - 1-Speed Pump	1.0	115	34	3 ft. Twist-Lock	621.32
<b>520-4020</b>	50 sq. ft. Filter - 1-Speed Pump with Trap	1.5	115	36	3 ft. Twist-Lock	669.64



## Pool Filters - In-Ground / UltraClean Pro - Sand

### FEATURES:

- Durable roto-molded tank is designed for extra sand-holding capacity
- One-piece corrosion-proof body
- Special Lateral design provides superior flow and long filter cycles for better efficiency
- Fine-spray internal diffuser for even water distribution

*UltraClean Pro Sand Filters are designed for in-ground applications and feature hefty corrosion-proof polymeric bodies and extra-large sand-holding capacity. UltraClean Pro filters will provide clear, sparkling water with trouble-free operation and only minimal maintenance.*



*For replacement parts, see page 250.*

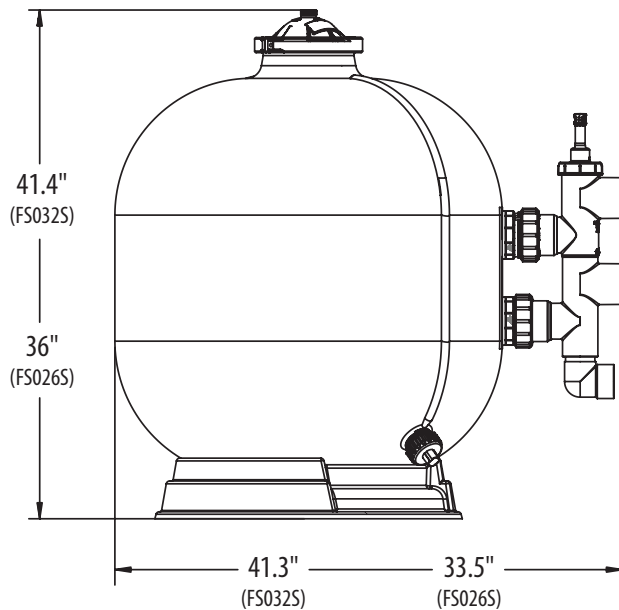

### Ultra-Clean Pro Sand Filters

Part No.	Description	Filtration Area	Flow Rate	Sand Weight	Pool Turnover (6 hrs. - 8 hrs.)	List (US \$)
<b>FS026S</b>	26" UltraClean Pro Sand Filter - Side Mount	3.5 sq. ft.	70 GPM	400 lbs.	25,200 - 33,600	1135.28
<b>FS032S</b>	32" UltraClean Pro Sand Filter - Side Mount	5.1 sq. ft.	106 GPM	600 lbs.	38,160 - 50,880	1397.14
<b>600-1500UCP</b>	UltraClean Pro 2 1/2" Slide Valve Assembly	--	--	--	--	134.15
<b>WVD001UCP</b>	Multi-Port Valve with Unions - 2" FTP - Sand	--	--	--	--	217.23
<b>WVD002UCP</b>	Multi-Port Valve with Unions - 2" Socket - Sand	--	--	--	--	217.23



**FEATURES:**

- Durable roto-molded tank is designed for extra sand-holding capacity
- One-piece, corrosion-proof body
- 2" FPT clamp style multi-port valve
- Special lateral design provides superior flow and long filter cycles for better efficiency
- Fine-spray internal diffuser for even water distribution

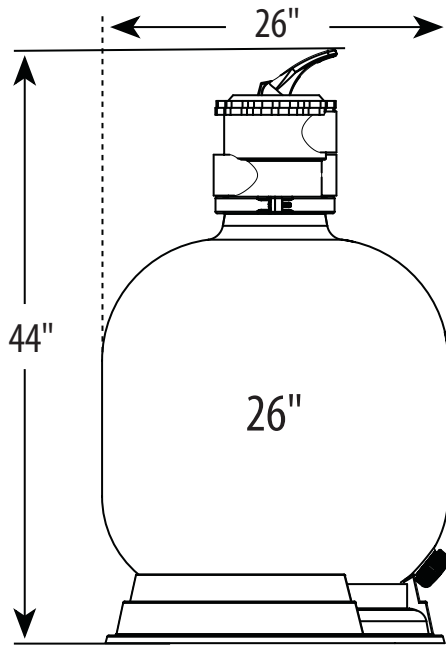

*SmartClean Sand Filters are the latest innovation in pool filter technology with large corrosion-proof polymeric bodies, designed for extra sand-holding capacity. SmartClean Sand Filters will provide clear, sparkling water with trouble-free operation and only minimal maintenance.*

*For replacement parts, see page 252.*

**SmartClean Sand Filters**

Part No.	Description	Filtration Area	Flow Rate	Sand Weight	Pool Turnover (6 hrs. - 8 hrs. - 10 hrs.)	List (US \$)
<b>FS02629TV2</b>	26" diameter Filter with 2" FPT Valve	3.5 sq. ft.	70 GPM	400 lbs.	25,200 - 33,600 - 42,000	1135.28

**Multi-Port Valves**

Part No.	Description	List (US \$)
<b>WVS004</b>	Top Mount Clamp Style - 2" FPT	168.66





## Pool Filters - In-Ground & Above Ground / Carefree Top-Mount - Sand

### FEATURES:

- Large filter with extra sand-holding capacity
- Durable roto-molded oval tank body distributes the pressure evenly resulting in greater strength and longer life of the filter
- One-piece corrosion proof body
- High Flow internal diffuser for even water distribution
- 7-function Top-Mount 1 1/2" FPT Multi-Port Valve with Split-Nut Lock Union (WVS003)
- 1 1/2" drain port
- Mounting base included

Carefree Top-Mount Sand Filters are designed for extra sand holding capacity. Made of corrosion-proof polymeric thermoplastic. The Carefree Sand Filter offers the ideal combination of energy efficiency and excellent water clarity. This filter is an excellent choice for above ground or in-ground pools.



For replacement parts, see page 253.  
For equipment bases, see page 11.

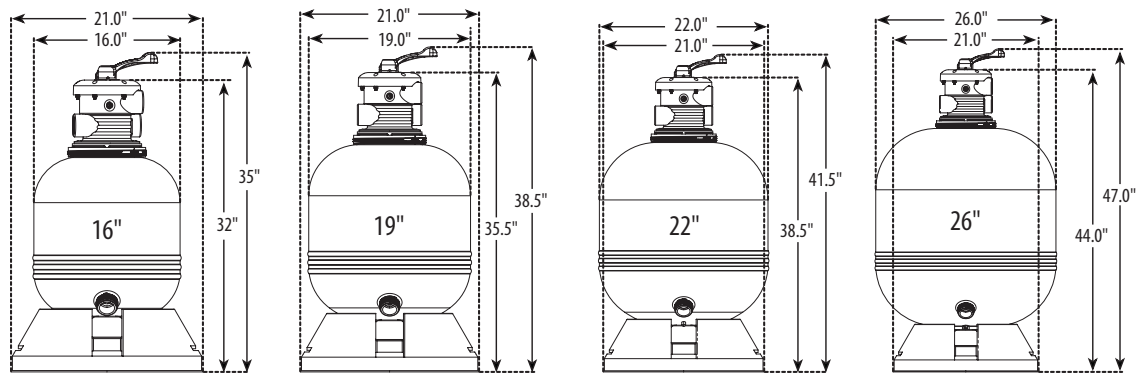

### Sand Required

16" - 100 lbs.

19" - 150 lbs.

22" - 250 lbs.

26" - 400 lbs.

### Carefree Top-Mount Sand Filters

Part No.	Description	Multi-Port Valve Style	Filtration Area	Flow Rate	Pool Turnover (6 hrs., 8 hrs, 10 hrs.)	List (US \$)
<b>FS01619</b>	16" diameter Filter with Modular Base	1 1/2" FPT Split-Nut	1.4 sq. ft.	35 GPM	12,600 - 16,800 - 21,000	483.76
<b>FS01922</b>	19" diameter Filter with Modular Base	1 1/2" FPT Split-Nut	2.0 sq. ft.	45 GPM	16,200 - 21,600 - 27,000	525.24
<b>FS02225</b>	22" diameter Filter with Modular Base	1 1/2" FPT Split-Nut	2.6 sq. ft.	55 GPM	19,800 - 26,400 - 33,000	608.17
<b>FS02629</b>	26" diameter Filter with Modular Base	1 1/2" FPT Split-Nut	3.5 sq. ft.	70 GPM	25,200 - 33,600 - 42,000	704.93



## FEATURES:

- Large filter with extra sand-holding capacity
- Top-of-the-line Supreme High Performance Single and Dual Speed Pump
- Extra large 7" pump trap with clear lid
- Union connection on multi-port for easy installation
- Unionized gate valve to isolate the system for maintenance
- Two 1 1/2" diameter hoses with clamps
- Filter and pump mounting bases
- Fittings package for all connections
- Accessory base allows for addition of optional timer and/or chlorinator kits for minimal maintenance (*sold separately*)
- Dual speed pump meets CEC Title 20 Code - Effective January 1, 2008



Carefree Sand Filter Systems are designed with the ideal combination of energy efficiency and excellent water clarity. The Carefree Sand Filter and Pump Pack System provides everything needed for an above ground pool package.



## Carefree Sand Deluxe System with Supreme 2-Speed Pump

Part No.	Filter	Diameter	Filtration Area	Flow Rate	Pump	HP	Cord	List (US \$)
<b>FSS016910-3</b>	FS01619	16"	1.4 sq. ft.	35 GPM	PSP2100-3	1.0	3 ft. TL	919.00
<b>FSS019910-3</b>	FS01922	19"	2.0 sq. ft.	45 GPM	PSP2100-3	1.0	3 ft. TL	968.44
<b>FSS022915-3</b>	FS02225	22"	2.6 sq. ft.	55 GPM	PSP2150-3	1.5	3 ft. TL	1105.99
<b>FSS026915-3</b>	FS02629	26"	3.5 sq. ft.	70 GPM	PSP2150-3	1.5	3 ft. TL	1206.73
<b>FSS016910-6</b>	FS01619	16"	1.4 sq. ft.	35 GPM	PSP2100-6	1.0	6 ft. NEMA	919.00
<b>FSS019910-6</b>	FS01922	19"	2.0 sq. ft.	45 GPM	PSP2100-6	1.0	6 ft. NEMA	968.44
<b>FSS022915-6</b>	FS02225	22"	2.6 sq. ft.	55 GPM	PSP2150-6	1.5	6 ft. NEMA	1105.99
<b>FSS026915-6</b>	FS02629	26"	3.5 sq. ft.	70 GPM	PSP2150-6	1.5	6 ft. NEMA	1206.73

## INCLUDES:

- 2 hoses (1 1/2" x 6 ft.)
- Filter / Pump Hose with Union Adapters, Hose fittings and hose clamps
- 3 ft. cord Twist-Lock plug (NEC/UL), or 6 ft. cord NEMA plug
- Deluxe modular filter and pump bases
- Unionized gate valve to isolate the system for maintenance

## Carefree Sand Deluxe System with Supreme 1-Speed Pump

Part No.	Filter	Diameter	Filtration Area	Flow Rate	Pump	HP	Cord	List (US \$)
<b>FSS016910-3S</b>	FS01619	16"	1.4 sq. ft.	35 GPM	PSP1100-3	1.0	3 ft. TL	822.00
<b>FSS019910-3S</b>	FS01922	19"	2.0 sq. ft.	45 GPM	PSP1100-3	1.0	3 ft. TL	871.94
<b>FSS022915-3S</b>	FS02225	22"	2.6 sq. ft.	55 GPM	PSP1150-3	1.5	3 ft. TL	980.42
<b>FSS026915-3S</b>	FS02629	26"	3.5 sq. ft.	70 GPM	PSP1150-3	1.5	3 ft. TL	1091.16
<b>FSS016910-6S</b>	FS01619	16"	1.4 sq. ft.	35 GPM	PSP1100-6	1.0	6 ft. NEMA	822.00
<b>FSS019910-6S</b>	FS01922	19"	2.0 sq. ft.	45 GPM	PSP1100-6	1.0	6 ft. NEMA	871.94
<b>FSS022915-6S</b>	FS02225	22"	2.6 sq. ft.	55 GPM	PSP1150-6	1.5	6 ft. NEMA	980.42
<b>FSS026915-6S</b>	FS02629	26"	3.5 sq. ft.	70 GPM	PSP1150-6	1.5	6 ft. NEMA	1091.16

## INCLUDES:

- 2 hoses (1 1/2" x 6 ft.)
- Filter / Pump Hose with Union Adapters, Hose fittings and hose clamps
- 3 ft. cord Twist-Lock plug (NEC/UL), or 6 ft. cord NEMA plug
- Deluxe modular filter and pump bases
- Unionized gate valve to isolate the system for maintenance

## Carefree Sand Deluxe System (without Supreme Pump)

Part No.	Filter	Diameter	Filtration Area	Flow Rate	List (US \$)
<b>FSS0169S</b>	FS01619	16"	1.4 sq. ft.	35 GPM	454.41
<b>FSS0199S</b>	FS01921	19"	2.0 sq. ft.	45 GPM	526.35
<b>FSS0229S</b>	FS02225	22"	2.6 sq. ft.	55 GPM	673.29
<b>FSS0269S</b>	FS02629	26"	3.5 sq. ft.	70 GPM	783.00

## INCLUDES:

- 2 hoses (1 1/2" x 6 ft.)
- Filter / Pump Hose with Union Adapters, Hose fittings and hose clamps
- Deluxe modular filter and pump bases
- Unionized gate valve to isolate the system for maintenance



## Pool Filters - Above Ground / Carefree Top-Mount - Sand Standard System

Carefree Sand Filter Systems are designed with the ideal combination of energy efficiency and excellent water clarity. The Carefree Sand Filter and Pump Pack System provides everything needed for an above ground pool package.

### FEATURES:

- Large filter with extra sand-holding capacity
- Hi-Flo High Performance Single and Dual Speed Pump
- Large 6" pump trap with one-piece clear lid
- Standard pump and filter base
- Fittings package for all connections
- Dual speed pump meets CEC Title 20 Code - Effective January 1, 2008



### INCLUDES:

- 2 hoses (1 1/2" x 6 ft.)
- Filter / Pump Hose with Union Adapters, Hose fittings and hose clamps
- 3 ft. cord Twist-Lock plug (NEC/UL), or 6 ft. cord NEMA plug
- Standard system base

### Carefree Sand Standard System with Hi-Flo 2-Speed Pump

Part No.	Filter	Diameter	Filtration Area	Flow Rate	Pump	HP	Cord	List (US \$)
<b>522-5300-3S</b>	FS01619	16"	1.4 sq. ft.	35 GPM	PH2100-3	1.0	3 ft. TL	850.60
<b>522-5320-3S</b>	FS01922	19"	2.0 sq. ft.	45 GPM	PH2100-3	1.0	3 ft. TL	900.54
<b>522-5330-3S</b>	FS01922	19"	2.0 sq. ft.	45 GPM	PH2150-3	1.5	3 ft. TL	918.65
<b>522-5350-3S</b>	FS02225	22"	2.6 sq. ft.	55 GPM	PH2100-3	1.0	3 ft. TL	1008.07
<b>522-5340-3S</b>	FS02225	22"	2.6 sq. ft.	55 GPM	PH2150-3	1.5	3 ft. TL	1037.57
<b>522-5300-6S</b>	FS01619	16"	1.4 sq. ft.	35 GPM	PH2100-6	1.0	6 ft. NEMA	850.60
<b>522-5320-6S</b>	FS01922	19"	2.0 sq. ft.	45 GPM	PH2100-6	1.0	6 ft. NEMA	900.54
<b>522-5330-6S</b>	FS01922	19"	2.0 sq. ft.	45 GPM	PH2150-6	1.5	6 ft. NEMA	918.65
<b>522-5350-6S</b>	FS02225	22"	2.6 sq. ft.	55 GPM	PH2100-6	1.0	6 ft. NEMA	1008.07
<b>522-5340-6S</b>	FS02225	22"	2.6 sq. ft.	55 GPM	PH2150-6	1.5	6 ft. NEMA	1037.57

### INCLUDES:

- 2 hoses (1 1/2" x 6 ft.)
- Filter / Pump Hose with Union Adapters, Hose fittings and hose clamps
- 3 ft. cord Twist-Lock plug (NEC/UL), or 6 ft. cord NEMA plug
- Standard system base

### Carefree Sand Standard System with Hi-Flo 1-Speed Pump

Part No.	Filter	Diameter	Filtration Area	Flow Rate	Pump	HP	Cord	List (US \$)
<b>520-5300-3S</b>	FS01619	16"	1.4 sq. ft.	35 GPM	PH1100-3	1.0	3 ft. TL	751.60
<b>520-5320-3S</b>	FS01922	19"	2.0 sq. ft.	45 GPM	PH1100-3	1.0	3 ft. TL	804.54
<b>520-5330-3S</b>	FS01922	19"	2.0 sq. ft.	45 GPM	PH1150-3	1.5	3 ft. TL	822.65
<b>520-5350-3S</b>	FS02225	22"	2.6 sq. ft.	55 GPM	PH1100-3	1.0	3 ft. TL	912.07
<b>520-5340-3S</b>	FS02225	22"	2.6 sq. ft.	55 GPM	PH1150-3	1.5	3 ft. TL	941.57
<b>520-5300-6S</b>	FS01619	16"	1.4 sq. ft.	35 GPM	PH1100-6	1.0	6 ft. NEMA	754.60
<b>520-5320-6S</b>	FS01922	19"	2.0 sq. ft.	45 GPM	PH1100-6	1.0	6 ft. NEMA	804.54
<b>520-5330-6S</b>	FS01922	19"	2.0 sq. ft.	45 GPM	PH1150-6	1.5	6 ft. NEMA	822.65
<b>520-5350-6S</b>	FS02225	22"	2.6 sq. ft.	55 GPM	PH1100-6	1.0	6 ft. NEMA	912.07
<b>520-5340-6S</b>	FS02225	22"	2.6 sq. ft.	55 GPM	PH1150-6	1.5	6 ft. NEMA	941.57



**FEATURES:**

- Durable roto-molded tank body is spherical to evenly distribute the pressure resulting in greater strength and longer life of the filter
- Corrosion-proof body
- High Flow internal diffuser for even water distribution
- 7-function Top-Mount 1 1/2" FPT Multi-Port Valve with Split-Nut Lock Union
- 1 1/2" drain port
- Mounting base included

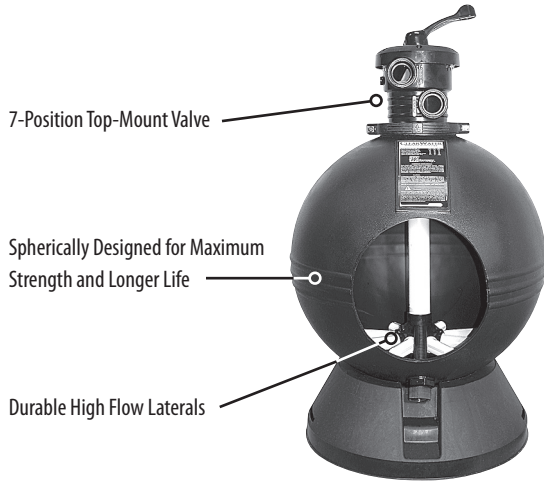

*Rugged, corrosion proof, high filtration area, and one-piece body. The ClearWater Sand filter features a seven-function top mount valve for maximum control over the filter system, and full flow, self cleaning laterals with large surface area for maximum flow. This filter is an excellent choice for above ground or in-ground pools.*

*For replacement parts, see page 255.  
For equipment bases, see page 11.*

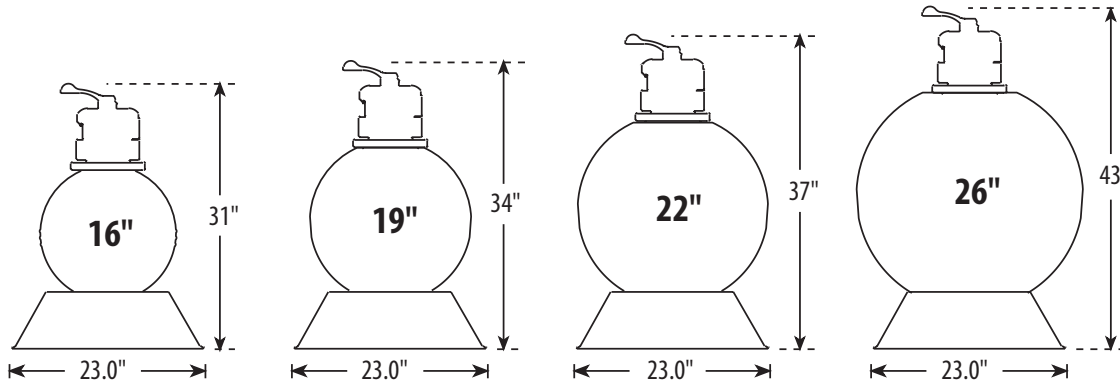

Sand Required			
16" - 50 lbs.	19" - 100 lbs.	22" - 150 lbs.	26" - 200 lbs.

**ClearWater Sand Filter**

Part No.	Description	Filtration Area	Flow Rate	Pool Turnover (6 hrs.)	Pool Turnover (8 hrs.)	Weight (lbs.)	List (US \$)
<b>FS016</b>	16" diameter Filter	1.4 sq. ft.	35 GPM	12,600	16,800	25	401.66
<b>FS019</b>	19" diameter Filter	2.0 sq. ft.	45 GPM	16,200	21,600	28	465.55
<b>FS022</b>	22" diameter Filter	2.6 sq. ft.	55 GPM	19,800	26,400	34	517.93
<b>FS026</b>	26" diameter Filter	3.5 sq. ft.	70 GPM	25,200	33,600	43	783.00

*1 1/2" FPT split-nut style clamp included.*



## Pool Filters - Above Ground / ClearWater - Sand Deluxe 2-Speed System

### FEATURES:

- Large filtration sand filter with durable, high flow laterals
- Top-of-the-Line Supreme High Performance Dual Speed Pump
- Extra large 7" pump trap with clear lid
- Union connection on multi-port for easy installation
- Unionized gate valve to isolate the system for maintenance
- Two 1 1/2" diameter hoses with clamps
- Filter and pump mounting base
- Fittings package for all connections
- Accessory base allows for addition of optional timer and/or chlorinator kits for minimal maintenance (sold separately)
- Dual speed pump meets CEC Title 20 Code - Effective January 1, 2008



Complete the Sand filtration system with the high performance Waterway Supreme Pump and accessories. The Sand Filter and Pump Pack provides homeowners with everything they need to get their system up and running. It assures them of matched components and optimal performance with years of dependable service.



### INCLUDES:

- 2 hoses (1 1/2" x 6 ft.)
- Filter / Pump Hose with Union Adapters, Hose fittings and hose clamps
- 3 ft. cord Twist-Lock plug (NEC/UL), or 6 ft. cord NEMA plug
- Deluxe modular filter and pump base
- Unionized gate valve to isolate the system for maintenance
- Accessory base for optional timer and/or chlorinator

### ClearWater Sand Deluxe System with Supreme 2-Speed Pump

Part No.	Filter	Diameter	Filtration Area	Flow Rate	Pump	HP	Cord	List (US \$)
<b>FSS01910-3</b>	FS019	19"	2.0 sq. ft.	45 GPM	PSP2100-3	1.0	3 ft. Twist-Lock	893.15
<b>FSS01915-3</b>	FS019	19"	2.0 sq. ft.	45 GPM	PSP2150-3	1.5	3 ft. Twist-Lock	933.74
<b>FSS02210-3</b>	FS022	22"	2.6 sq. ft.	55 GPM	PSP2100-3	1.0	3 ft. Twist-Lock	985.39
<b>FSS02215-3</b>	FS022	22"	2.6 sq. ft.	55 GPM	PSP2150-3	1.5	3 ft. Twist-Lock	1025.98
<b>FSS02615-3</b>	FS026	26"	3.5 sq. ft.	70 GPM	PSP2150-3	1.5	3 ft. Twist-Lock	1119.11
<b>FSS01910-6</b>	FS019	19"	2.0 sq. ft.	45 GPM	PSP2100-6	1.0	6 ft. NEMA	893.15
<b>FSS01915-6</b>	FS019	19"	2.0 sq. ft.	45 GPM	PSP2150-6	1.5	6 ft. NEMA	933.74
<b>FSS02210-6</b>	FS022	22"	2.6 sq. ft.	55 GPM	PSP2100-6	1.0	6 ft. NEMA	985.39
<b>FSS02215-6</b>	FS022	22"	2.6 sq. ft.	55 GPM	PSP2150-6	1.5	6 ft. NEMA	1025.98
<b>FSS02615-6</b>	FS026	26"	3.5 sq. ft.	70 GPM	PSP2150-6	1.5	6 ft. NEMA	1119.11

### INCLUDES:

- 2 hoses (1 1/2" x 6 ft.)
- Filter / Pump Hose with Union Adapters, Hose fittings and hose clamps
- Deluxe modular filter and pump base
- Unionized gate valve to isolate the system for maintenance
- Accessory base for optional timer and/or chlorinator

### ClearWater Sand Deluxe System (without Supreme Pump)

Part No.	Filter	Diameter	Filtration Area	Flow Rate	List (US \$)
<b>FSS019S</b>	FS019	19"	2.0 sq. ft.	45 GPM	592.23
<b>FSS022S</b>	FS022	22"	2.6 sq. ft.	55 GPM	677.68
<b>FSS026S</b>	FS026	26"	3.5 sq. ft.	70 GPM	781.32



**FEATURES:**

- Large filtration sand filter with durable, high flow laterals
- Top-of-the-Line Supreme High Performance Pump
- Extra large 7" pump trap with clear lid
- Union connection on multi-port for easy installation
- Unionized gate valve to isolate the system for maintenance
- Two 1 1/2" diameter hoses with clamps
- Filter and pump mounting bases
- Fittings package for all connections
- Accessory base allows for addition of optional timer and/or chlorinator kits for minimal maintenance (sold separately)



Complete the Sand filtration system with the high performance Waterway Supreme Pump and accessories. The Sand Filter and Pump Pack provides homeowners with everything they need to get their system up and running. It assures them of matched components and optimal performance with years of dependable service.

**ClearWater Sand Deluxe System with Supreme 1-Speed Pump**

Part No.	Filter	Diameter	Filtration Area	Flow Rate	Pump	HP	Cord	List (US \$)
<b>FSS01910-3S</b>	FS019	19"	2.0 sq. ft.	45 GPM	PSP1100-3	1.0	3 ft. Twist-Lock	796.15
<b>FSS01915-3S</b>	FS019	19"	2.0 sq. ft.	45 GPM	PSP1150-3	1.5	3 ft. Twist-Lock	836.74
<b>FSS02210-3S</b>	FS022	22"	2.6 sq. ft.	55 GPM	PSP1100-3	1.0	3 ft. Twist-Lock	859.82
<b>FSS02215-3S</b>	FS022	22"	2.6 sq. ft.	55 GPM	PSP1150-3	1.5	3 ft. Twist-Lock	900.41
<b>FSS02615-3S</b>	FS026	26"	3.5 sq. ft.	70 GPM	PSP1150-3	1.5	3 ft. Twist-Lock	1003.54
<b>FSS01910-6S</b>	FS019	19"	2.0 sq. ft.	45 GPM	PSP1100-6	1.0	6 ft. NEMA	796.15
<b>FSS01915-6S</b>	FS019	19"	2.0 sq. ft.	45 GPM	PSP1150-6	1.5	6 ft. NEMA	836.74
<b>FSS02210-6S</b>	FS022	22"	2.6 sq. ft.	55 GPM	PSP1100-6	1.0	6 ft. NEMA	859.82
<b>FSS02215-6S</b>	FS022	22"	2.6 sq. ft.	55 GPM	PSP1150-6	1.5	6 ft. NEMA	900.41
<b>FSS02615-6S</b>	FS026	26"	3.5 sq. ft.	70 GPM	PSP1150-6	1.5	6 ft. NEMA	1003.54

**INCLUDES:**

- 2 hoses (1 1/2" x 6 ft.)
- Filter / Pump Hose with Union Adapters, Hose fittings and hose clamps
- 3 ft. cord Twist-Lock plug (NEC/UL), or 6 ft. cord NEMA plug
- Deluxe modular filter and pump base
- Unionized gate valve to isolate the system for maintenance

**ClearWater Sand Deluxe System (without Supreme Pump)**

Part No.	Filter	Diameter	Filtration Area	Flow Rate	List (US \$)
<b>FSS019S</b>	FS019	19"	2.0 sq. ft.	45 GPM	592.23
<b>FSS022S</b>	FS022	22"	2.6 sq. ft.	55 GPM	677.68
<b>FSS026S</b>	FS026	26"	3.5 sq. ft.	70 GPM	781.32

**INCLUDES:**

- 2 hoses (1 1/2" x 6 ft.)
- Filter / Pump Hose with Union Adapters, Hose fittings and hose clamps
- Deluxe modular filter and pump base
- Unionized gate valve to isolate the system for maintenance



## Pool Filters - Above Ground / ClearWater - Sand Standard System

Complete the Sand filtration system with the high performance Waterway Hi-Flo Pump and accessories. The Sand Filter and Pump Pack provides homeowners with everything they need to get their system up and running. It assures them of matched components and optimal performance with years of dependable service.

### FEATURES:

- Large filtration sand filter with durable, high flow laterals
- Hi-Flo High Performance Single and Dual Speed Pump
- Large 6" pump trap with one-piece clear lid
- Union connection on multi-port for easy installation
- Two 1 1/2" diameter hoses with clamps
- Dual speed pump meets CEC Title 20 Code - Effective January 1, 2008



### INCLUDES:

- 2 hoses (1 1/2" x 6 ft.)
- Filter / Pump Hose with Union Adapters, Hose fittings and hose clamps
- 3 ft. cord Twist-Lock plug (NEC/UL), or 6 ft. cord NEMA plug
- Standard system base

### ClearWater Sand Standard System with Hi-Flo 2-Speed Pump

Part No.	Filter	Diameter	Filtration Area	Flow Rate	Pump	HP	Cord	List (US \$)
<b>522-5200-3S</b>	FS016	16"	1.4 sq. ft.	35 GPM	PH2100-3	1.0	3 ft. TL	792.65
<b>522-5220-3S</b>	FS019	19"	2.0 sq. ft.	45 GPM	PH2100-3	1.0	3 ft. TL	824.75
<b>522-5240-3S</b>	FS022	22"	2.6 sq. ft.	55 GPM	PH2150-3	1.5	3 ft. TL	957.52
<b>522-5260-3S</b>	FS026	26"	3.5 sq. ft.	70 GPM	PH2150-3	1.5	3 ft. TL	1050.69
<b>522-5200-6S</b>	FS016	16"	1.4 sq. ft.	35 GPM	PH2100-6	1.0	6 ft. NEMA	792.65
<b>522-5220-6S</b>	FS019	19"	2.0 sq. ft.	45 GPM	PH2100-6	1.0	6 ft. NEMA	824.75
<b>522-5240-6S</b>	FS022	22"	2.6 sq. ft.	55 GPM	PH2150-6	1.5	6 ft. NEMA	959.56
<b>522-5260-6S</b>	FS026	26"	3.5 sq. ft.	70 GPM	PH2150-6	1.5	6 ft. NEMA	1050.69

### INCLUDES:

- 2 hoses (1 1/2" x 6 ft.)
- Filter / Pump Hose with Union Adapters, Hose fittings and hose clamps
- 3 ft. cord Twist-Lock plug (NEC/UL), or 6 ft. cord NEMA plug
- Standard system base

### ClearWater Sand Standard System with Hi-Flo 1-Speed Pump

Part No.	Filter	Diameter	Filtration Area	Flow Rate	Pump	HP	Cord	List (US \$)
<b>520-5200-3S</b>	FS016	16"	1.4 sq. ft.	35 GPM	PH1100-3	1.0	3 ft. TL	696.65
<b>520-5220-3S</b>	FS019	19"	2.0 sq. ft.	45 GPM	PH1100-3	1.0	3 ft. TL	728.75
<b>520-5240-3S</b>	FS022	22"	2.6 sq. ft.	55 GPM	PH1150-3	1.5	3 ft. TL	861.56
<b>520-5260-3S</b>	FS026	26"	3.5 sq. ft.	70 GPM	PH1150-3	1.5	3 ft. TL	936.14
<b>520-5200-6S</b>	FS016	16"	1.4 sq. ft.	35 GPM	PH1100-6	1.0	6 ft. NEMA	696.65
<b>520-5220-6S</b>	FS019	19"	2.0 sq. ft.	45 GPM	PH1100-6	1.0	6 ft. NEMA	728.75
<b>520-5240-6S</b>	FS022	22"	2.6 sq. ft.	55 GPM	PH1150-6	1.5	6 ft. NEMA	861.56
<b>520-5260-6S</b>	FS026	26"	3.5 sq. ft.	70 GPM	PH1150-6	1.5	6 ft. NEMA	936.14

### INCLUDES:

- 2 hoses (1 1/2" x 6 ft.)
- Filter / Pump Hose with Union Adapters, Hose fittings and hose clamps
- Standard system base

### ClearWater Sand Standard System (without Hi-Flo Pump)

Part No.	Filter	Diameter	Filtration Area	Flow Rate		List (US \$)
<b>520-5200</b>	FS016	16"	1.4 sq. ft.	35 GPM		497.87
<b>520-5220</b>	FS019	19"	2.0 sq. ft.	45 GPM		566.19
<b>520-5240</b>	FS022	22"	2.6 sq. ft.	55 GPM		638.58
<b>520-5260</b>	FS026	26"	3.5 sq. ft.	70 GPM		755.63



**FEATURES:**

- Filter, pump, hoses and fittings in one box
- Choice of tank and pump sizes
- Spherical tank design evenly distributes pressure and stress resulting in greater strength and longer life
- Corrosion-proof sand filter tank
- 7 position Multi-Port Valve
- Center discharge pump with leaf trap - Single and Dual Speed
- Dual speed pump meets CEC Title 20 Code - Effective January 1, 2008

*The economical solution for filtering with a sand filter on an above ground pool. Designed to handle virtually all sizes and conditions, the Waterway TWM Sand Filter systems will provide years of dependable filtration.*



For replacement parts, see page 257.

## TWM Sand Filter Equipment Packages - 2-Speed

Part No.	Description	Filtration	Flow Rate	Turnover (8 - 10 hrs.)	Sand (lbs.)	Cord	List (US \$)
<b>522-1610</b>	16" Sand Filter - 1 HP Center Discharge Pump	1.4 sq. ft.	30 GPM	14,400 - 18,000	50	3 ft. NEMA	736.39
<b>522-1910</b>	19" Sand Filter - 1 HP Center Discharge Pump	2.0 sq. ft.	42 GPM	20,160 - 25,200	100	3 ft. NEMA	770.38
<b>522-1700</b>	22" Sand Filter - 1.5 HP Center Discharge Pump	2.5 sq. ft.	50 GPM	24,000 - 30,000	150	3 ft. NEMA	815.70
<b>522-1610-3</b>	16" Sand Filter - 1 HP Center Discharge Pump	1.4 sq. ft.	30 GPM	14,400 - 18,000	50	3 ft. Twist-Lock	736.39
<b>522-1910-3</b>	19" Sand Filter - 1 HP Center Discharge Pump	2.0 sq. ft.	42 GPM	20,160 - 25,200	100	3 ft. Twist-Lock	770.38
<b>522-1700-3</b>	22" Sand Filter - 1.5 HP Center Discharge Pump	2.5 sq. ft.	50 GPM	24,000 - 30,000	150	3 ft. Twist-Lock	815.70

## TWM Sand Filter Equipment Packages - 1-Speed

Part No.	Description	Filtration	Flow Rate	Turnover (8 - 10 hrs.)	Sand (lbs.)	Cord	List (US \$)
<b>520-1610</b>	16" Sand Filter - 1 HP Center Discharge Pump	1.4 sq. ft.	30 GPM	14,400 - 18,000	50	3 ft. NEMA	640.39
<b>520-1910</b>	19" Sand Filter - 1 HP Center Discharge Pump	2.0 sq. ft.	42 GPM	20,160 - 25,200	100	3 ft. NEMA	674.38
<b>520-1700</b>	22" Sand Filter - 1.5 HP Center Discharge Pump	2.5 sq. ft.	50 GPM	24,000 - 30,000	150	3 ft. NEMA	719.70
<b>520-1610-3</b>	16" Sand Filter - 1 HP Center Discharge Pump	1.4 sq. ft.	30 GPM	14,400 - 18,000	50	3 ft. Twist-Lock	640.39
<b>520-1910-3</b>	19" Sand Filter - 1 HP Center Discharge Pump	2.0 sq. ft.	42 GPM	20,160 - 25,200	100	3 ft. Twist-Lock	674.38
<b>520-1700-3</b>	22" Sand Filter - 1.5 HP Center Discharge Pump	2.5 sq. ft.	50 GPM	24,000 - 30,000	150	3 ft. Twist-Lock	719.70