



Pool Filters - In-Ground / Crystal Water - D.E.

FEATURES:

- NSF Listed
- 2 ½" internal piping
- Fiberglass reinforced polypropylene body for superior strength
- "Multi-Handle" design
- Heavy-duty tamper-proof clamp
- Industry-proven D.E. grids
- "Start-Service" dial on stainless steel pressure gauge
- 1 ½" bottom clean-out port
- 2 ½" hi-temp PVC slide valve available
- 2 ½" x 2" Multi-Port Valves – available in Slip or FPT
- Convertible to cartridge by simply changing internals



For replacement parts, see page 306.

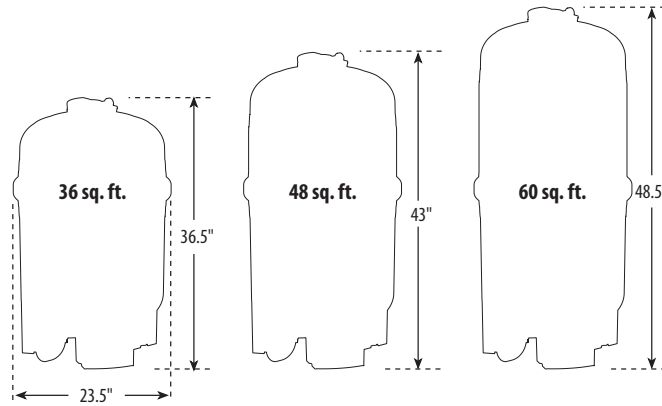

Crystal Water D.E. Filters

Part No.	Size	Flow Rate	Pool Turnover (6 hrs.)	Pool Turnover (8 hrs.)	Weight (lbs.)	List (US \$)
570-0036-07	36 sq. ft.	72 GPM	25,920	34,560	70	1,465.65
570-0048-07	48 sq. ft.	96 GPM	34,560	46,080	80	1,665.63
570-0060-07	60 sq. ft.	120 GPM	43,200	57,600	90	1,832.24



600-1500



WVD001

Valves for D.E. Filters

Part No.	Description	Case Quantity	Weight (lbs.)	List (US \$)
600-1500	2 ½" Hi-Temp PVC Slide Valve Assembly (2" and 1 ½" reducers included)	1	11	166.65
550-4280	Slide Valve Adapter Fitting Package for D.E. / Cartridge Filter (2" and 1 ½" reducers included)	1	--	51.90
WVD001	Multi-Port Valve with Union Connections - 2" FPT	1	13	269.86
WVD002	Multi-Port Valve with Union Connections - 2" Socket	1	13	269.86

Designed for today's most demanding installations, the Crystal Water D.E. Filter sets the standard of performance and features for pool filters. The only D.E. filter on the market with 2 ½" internal piping, improves flow and reduces system noise when using 2 ½", 2" or 1 ½" plumbing. From the lid with the "Multi-Handle" design to the 2" bottom clean out port, the Crystal Water D.E. Filter will provide years of trouble-free operation and crystal clear, sparkling water.



Pool Filters - In-Ground / Crystal Water - Cartridge

FEATURES:

- NSF Listed
- 2 1/2" internal piping
- 2 1/2" Valve Bulkhead Unions (includes 2" and 1 1/2" reducers)
- Fiberglass reinforced polypropylene body for superior strength
- "Multi-Handle" design
- Heavy-duty tamper-proof clamp with removal tool
- Industry proven quad-cartridge elements layout
- "Start-Service" dial on stainless steel pressure gauge
- 1 1/2" bottom clean-out port
- Convertible to D.E. by simply changing internals



Cluster of 4 cartridge elements for ease of maintenance and longer cleaning cycles.

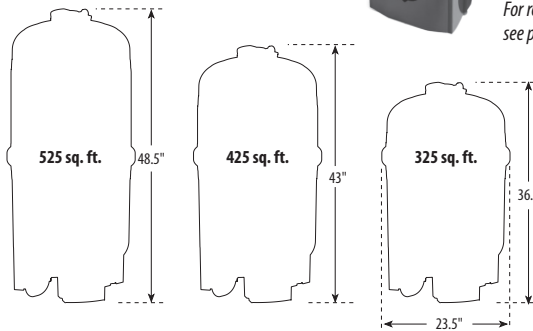

For replacement parts, see page 310.



Combining high tech features and an easy to service design, the Crystal Water Cartridge Filter is ideal for new and replacement installations. The only cartridge filter on the market with 2 1/2" internal piping, improves flow and reduces system noise when using 2 1/2", 2" or 1 1/2" plumbing. Using four cartridge elements, the Crystal Water Cartridge Filter offers a superior choice for easy maintenance and crystal clear, clean water.

Filters / Filter Systems

Crystal Water Cartridge Filters

Part No.	Size	NSF Flow Rate	Pool Turnover (6 hrs.)	Pool Turnover (8 hrs.)	Weight (lbs.)	List (US \$)
570-0325-07	325 sq. ft.	112 GPM	43,200	57,600	74	1,848.73
570-0425-07	425 sq. ft.	150 GPM	54,000	72,000	84	2,082.08
570-0525-07*	525 sq. ft.	150 GPM	54,000	72,000	92	2,415.21

*Ideal for longer cleaning cycles

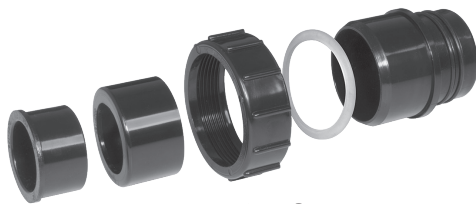

400-9974B

Bulkhead Fittings

Part No.	Description	Case Quantity	Weight (lbs.)	List (US \$)
421-4071B	Reducer - 1 1/2" to 2"	--	--	3.36
421-4201B	Reducer - 2 1/2" to 2"	--	--	7.18
415-4211B	2 1/2" Union Nut (2 required)	--	--	12.74
417-2201B	2 1/2" Tailpiece with Piston O-Ring Groove (2 required)	--	--	8.01
805-0232B	O-Ring - 2 1/2" Union (4 required - 2 for each Bulkhead)	--	--	2.13



Pool Filters - Above Ground / ClearWater II - D.E.

FEATURES:

- True Spiral Laminar flow for even disbursement of D.E.
- Automatic hydraulic regeneration
- High flow rate
- Modular grid system for easy maintenance
- Union gate valve with 1 1/2" hose adapter drain shut off
- Flush-mounted stainless steel pressure gauge
- Low-profile air relief plug
- Automatic air bleed capability
- Heavy-duty lid handle

True Spiral Laminar flow in an above ground filter. Spiral Laminar flow ensures even distribution of D.E. for maximum filtration. The ClearWater D.E. filter features automatic hydraulic regeneration, Waterway's Safety Lock Ring system for safe operation and maintenance, and a ten year warranty on its rugged glass-filled polymer body.

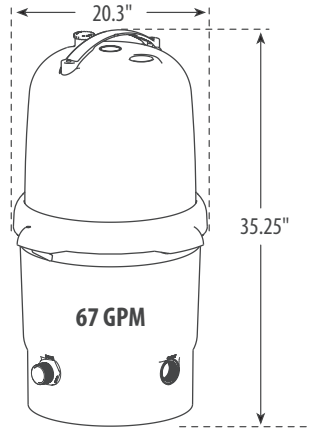
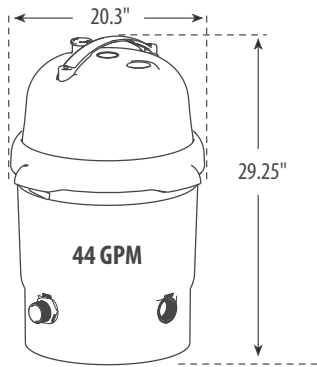

For replacement parts, see page 312.
For equipment bases, see page 55.

ClearWater II D.E. Filters

Part No.	Description	Filtration Area	Pool Turnover (6 hrs.)	Pool Turnover (8 hrs.)	Weight (lbs.)	List (US \$)
FD12-7	44 GPM Filter	12 sq. ft.	15,840	21,120	34	761.96
FD18-7	67 GPM Filter	18 sq. ft.	24,120	32,160	39	917.17

ClearWater II D.E. Accessories

Part No.	Description	Case Quantity	Weight (lbs.)	List (US \$)
672-7211	ClearWater Modular Filter Base - 7" x 23" Diameter	1	29	80.80
429-7300	Pin and Anchor Assembly Kit for Base	1	1	8.42

Pool Filters - Above Ground / ClearWater II - D.E. Deluxe System



FEATURES:

- True Spiral Laminar flow D.E. filter
- Top of the line Supreme High Performance Single or Dual Speed Pump
- Extra large 7" pump trap with clear lid
- Unionized gate valve to isolate the system for maintenance
- Drain Shut Off - Union Gate Valve with 1 1/2" hose adapter
- Two 1 1/2" diameter hoses with clamps
- Filter and pump mounting base, complete fitting package for all connections
- Accessory base (optional) allows for addition of optional timer and/or chlorinator kits for minimal maintenance
- Dual speed pump meets CEC Title 20 Code - Effective January 1, 2008



Complete the D.E. filtration system with the high performance Waterway Supreme Pump and accessories. The D.E. Filter and Pump Pack provides homeowners with everything they need to get their system up and running. It assures them of matched components and optimal performance with years of dependable service.

Filters / Filter Systems

ClearWater II D.E. Deluxe Systems - Supreme 1-Speed Pump

Part No.	Filter	Flow Rate	Pump	HP	Volts	Weight (lbs.)	Cord	List (US \$)
FDS044107-3S	FD12-7	44 GPM	PSP1100-3R	1.0	115	--	3 ft. Twist-Lock	1,338.82
FDS067107-3S	FD18-7	67 GPM	PSP1100-3R	1.0	115	76	3 ft. Twist-Lock	1,561.15
FDS067157-3S	FD18-7	67 GPM	PSP1150-3R	1.5	115	68	3 ft. Twist-Lock	1,959.70
FDS044107-6S	FD12-7	44 GPM	PSP1100-6R	1.0	115	--	3 ft. NEMA	1,338.82
FDS067107-6S	FD18-7	67 GPM	PSP1100-6R	1.0	115	--	3 ft. NEMA	1,560.80
FDS067157-6S	FD18-7	67 GPM	PSP1150-6R	1.5	115	--	3 ft. NEMA	1,959.28

INCLUDES:

- 2 hoses (1 1/2" x 6 ft.)
- Filter / Pump Union Adapter, Hose fittings and hose clamps
- 3 ft. cord Twist-Lock plug (NEC/UL), or 3 ft. cord NEMA plug
- 2 Unionized gate valves to isolate system for maintenance & drain
- Accessory base for optional timer and/or chlorinator

ClearWater II D.E. Deluxe Systems - Supreme 2-Speed Pump

Part No.	Filter	Flow Rate	Pump	HP	Volts	Weight (lbs.)	Cord	List (US \$)
FDS044107-3	FD12-7	44 GPM	PSP2100-3R	1.0	115	--	3 ft. Twist-Lock	1,521.47
FDS067107-3	FD18-7	67 GPM	PSP2100-3R	1.0	115	--	3 ft. Twist-Lock	1,896.42
FDS067157-3	FD18-7	67 GPM	PSP2150-3R	1.5	115	--	3 ft. Twist-Lock	1,932.64
FDS044107-6	FD12-7	44 GPM	PSP2100-6R	1.0	115	--	3 ft. NEMA	1,521.47
FDS067107-6	FD18-7	67 GPM	PSP2100-6R	1.0	115	--	3 ft. NEMA	1,896.42
FDS067157-6	FD18-7	67 GPM	PSP2150-6R	1.5	115	--	3 ft. NEMA	1,932.64

INCLUDES:

- 2 hoses (1 1/2" x 6 ft.)
- Filter / Pump Union Adapter, Hose fittings and hose clamps
- 3 ft. cord Twist-Lock plug (NEC/UL), or 3 ft. cord NEMA plug
- 2 Unionized gate valves to isolate system for maintenance & drain
- Accessory base for optional timer and/or chlorinator

ClearWater II D.E. Deluxe Systems (without Supreme Pump)

Part No.	Filter	Flow Rate	Weight (lbs.)	List (US \$)
FDS0447S	FD12-7	44 GPM	1	890.65
FDS0677S	FD18-7	67 GPM	1	1,266.80

INCLUDES:

- 2 hoses (1 1/2" x 6 ft.)
- Filter / Pump Union Adapter, Hose fittings and hose clamps
- 2 Unionized gate valves to isolate system for maintenance & drain
- Accessory base for optional timer and/or chlorinator

All power cords are 3' in length.



Pool Filters - Above Ground / ClearWater II - D.E. Standard System

FEATURES:

- True Spiral Laminar flow D.E. filter
- Hi-Flo II High Performance Single or Dual Speed Pump
- Large 6" pump trap with 2-piece lid
- Two 1 1/2" diameter hoses with clamps
- Complete fitting package for all connections
- Dual Speed meets CEC Title 20 Code - Effective January 1, 2008



The D.E. Filter and Pump Pack provides homeowners with everything they need to get their system up and running. It assures them of matched components and optimal performance with years of dependable service.

Filters / Filter Systems

INCLUDES:

- 2 Hoses (1 1/2" x 6 ft.)
- Filter / Pump Union Adapter, Hose fittings and hose clamps
- 3 ft. cord Twist-Lock plug (NEC/UL), or 3 ft. cord NEMA plug
- Standard system base

ClearWater II D.E. Standard Systems - Hi-Flo II 1-Speed Pump

Part No.	Filter	Flow Rate	Pump	HP	Volts	Weight (lbs.)	Cord	List (US \$)
520-5007-3S	FD12-7	44 GPM	PH1100-3R	1.0	115	70	3 ft. Twist-Lock	1,218.71
520-5027-3S	FD18-7	67 GPM	PH1100-3R	1.0	115	70	3 ft. Twist-Lock	1,411.90
520-5037-3S	FD18-7	67 GPM	PH1150-3R	1.5	115	70	3 ft. Twist-Lock	1,460.01
520-5007-6S	FD12-7	44 GPM	PH1100-6R	1.0	115	70	3 ft. NEMA	1,218.71
520-5027-6S	FD18-7	67 GPM	PH1100-6R	1.0	115	70	3 ft. NEMA	1,411.90
520-5037-6S	FD18-7	67 GPM	PH1150-6R	1.5	115	70	3 ft. NEMA	1,460.01

INCLUDES:

- 2 Hoses (1 1/2" x 6 ft.)
- Filter / Pump Union Adapter, Hose fittings and hose clamps
- 3 ft. cord Twist-Lock plug (NEC/UL), or 3 ft. cord NEMA plug
- Standard system base

ClearWater II D.E. Standard Systems - Hi-Flo II 2-Speed Pump

Part No.	Filter	Flow Rate	Pump	HP	Volts	Weight (lbs.)	Cord	List (US \$)
522-5007-3S	FD12-7	44 GPM	PH2100-3R	1.0	115	70	3 ft. Twist-Lock	1,293.71
522-5027-3S	FD18-7	67 GPM	PH2100-3R	1.0	115	--	3 ft. Twist-Lock	1,486.48
522-5037-3S	FD18-7	67 GPM	PH2150-3R	1.5	115	75	3 ft. Twist-Lock	1,539.12
522-5007-6S	FD12-7	44 GPM	PH2100-6R	1.0	115	70	3 ft. NEMA	1,293.72
522-5027-6S	FD18-7	67 GPM	PH2100-6R	1.0	115	70	3 ft. NEMA	1,486.96
522-5037-6S	FD18-7	67 GPM	PH2150-6R	1.5	115	70	3 ft. NEMA	1,539.12

INCLUDES:

- 2 Hoses (1 1/2" x 6 ft.)
- Filter / Pump Union Adapter, Hose fittings and hose clamps
- Standard system base

ClearWater II D.E. Standard Systems (without Hi-Flo II Pump)

Part No.	Filter	Flow Rate	List (US \$)
520-5007	FD12-7	44 GPM	867.16
520-5027	FD18-7	67 GPM	896.10

All power cords are 3' in length.



Pool Filters - Above Ground / ClearWater II - Cartridge

FEATURES:

- Wide-body filtration system
- Durable glass-filled polymer filter body
- Three year warranty on filter body
- 1 1/2" clean out drain on 1 1/2" FPT
- Flush-mounted stainless steel pressure gauge
- Low-profile air relief plug
- Heavy-duty lid handle

For replacement parts, see page 313.

For equipment bases, see page 55.



Large filtration, small footprint and high flow. ClearWater II Cartridge Filters incorporate wide-body filtration elements to give maximum filtration without sacrificing flow rate. Made of a durable glass-filled polymer, ClearWater II Cartridge Filters provide years of trouble free performance. ClearWater II Cartridge Filters feature Waterway's Safety Lock Ring system to ensure safe operation and easy maintenance.

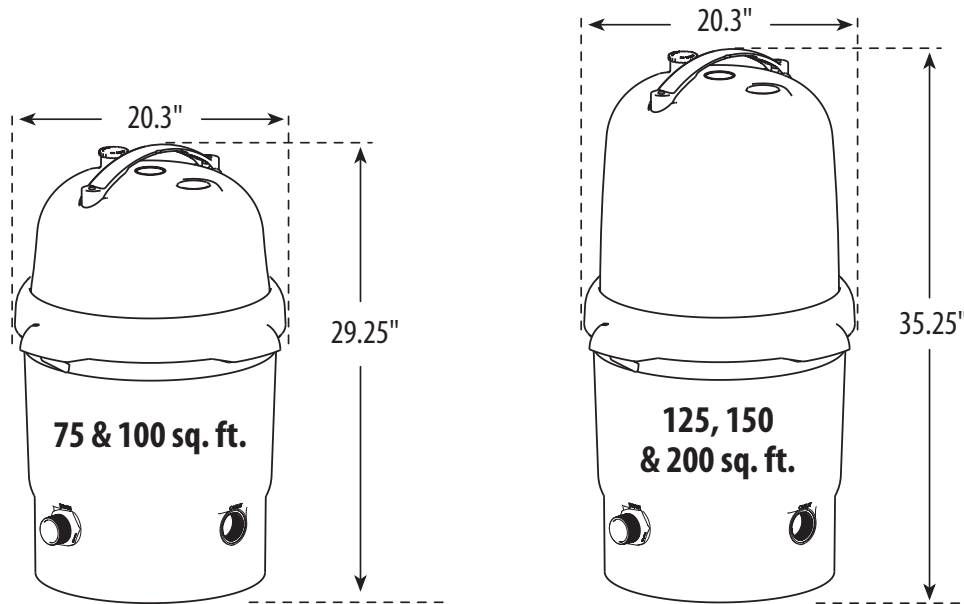

ClearWater II Cartridge Filters

Part No.	Filtration Area	Flow Rate	Pool Turnover (6 hrs.)	Pool Turnover (8 hrs.)	Weight (lbs.)	List (US \$)
FC0757	75 sq. ft.	75 GPM	27,000	36,000	46	667.38
FC1007	100 sq. ft.	100 GPM	36,000	48,000	34	856.52
FC1257	125 sq. ft.	125 GPM	45,000	60,000	34	918.21
FC1507	150 sq. ft.	150 GPM	54,000	72,000	59	1,152.75
FC2007*	200 sq. ft.	150 GPM	54,000	72,000	36	1,302.62

*Longer period between cleaning cycles



Pool Filters - Above Ground / **ClearWater II - Cartridge Deluxe System**

Complete the Cartridge filtration system with the Waterway Supreme High Performance Pump and accessories.

FEATURES:

- Large filtration, small footprint cartridge filter
- Top of the line Supreme High Performance Single or Dual Speed Pump
- Extra large 7" pump trap with clear lid
- Unionized gate valve to isolate the system for maintenance
- Two 1 1/2" diameter hoses with clamps
- Filter and pump mounting base
- Complete fitting package for all connections
- Accessory base allows for addition of optional timer and/or chlorinator kits for minimal maintenance
- Dual speed pump meets CEC Title 20 Code - Effective January 1, 2008



INCLUDES:

- 2 hoses (1 1/2" x 6 ft.)
- Filter / Pump Union Adapter, hose fittings and hose clamps
- 3 ft. cord Twist-Lock plug (NEC/UL), or 3 ft. cord NEMA plug
- Deluxe one-piece base system
- Unionized gate valve to isolate system for maintenance
- Accessory base for optional timer and/or chlorinator

ClearWater II Cartridge Deluxe System with Supreme 1-Speed Pump

Part No.	Filter	Filtration Area	Pump	HP	Volts	Weight (lbs.)	Cord	List (US \$)
FCS075107-3S	FC0757	75 sq. ft.	PSP1100-3R	1.0	115	69	3 ft. Twist-Lock	1,195.70
FCS100107-3S	FC1007	100 sq. ft.	PSP1100-3R	1.0	115	--	3 ft. Twist-Lock	1,601.56
FCS125157-3S	FC1257	125 sq. ft.	PSP1150-3R	1.5	115	--	3 ft. Twist-Lock	1,494.85
FCS150157-3S	FC1507	150 sq. ft.	PSP1150-3R	1.5	115	72	3 ft. Twist-Lock	1,593.93
FCS200157-3S	FC2007	200 sq. ft.	PSP1150-3R	1.5	115	--	3 ft. Twist-Lock	1,746.09
FCS075107-6S	FC0757	75 sq. ft.	PSP1100-6R	1.0	115	--	3 ft. NEMA	1,195.45
FCS100107-6S	FC1007	100 sq. ft.	PSP1100-6R	1.0	115	74	3 ft. NEMA	1,362.10
FCS100137-6S	FC1007	100 sq. ft.	PSP1075-6R	0.75	115	74	3 ft. NEMA	1,268.34
FCS125157-6S	FC1257	125 sq. ft.	PSP1150-6R	1.5	115	--	3 ft. NEMA	1,494.85
FCS150157-6S	FC1507	150 sq. ft.	PSP1150-6R	1.5	115	72	3 ft. NEMA	1,593.93
FCS200137-6S	FC2007	200 sq. ft.	PSP1075-6R	0.75	115	78	3 ft. NEMA	1,515.84
FCS200157-6S	FC2007	200 sq. ft.	PSP1150-6R	1.5	115	--	3 ft. NEMA	1,746.09

INCLUDES:

- 2 hoses (1 1/2" x 6 ft.)
- Filter / Pump Union Adapter, hose fittings and hose clamps
- 3 ft. cord Twist-Lock plug (NEC/UL), or 3 ft. cord NEMA plug
- Deluxe one-piece base system
- Unionized gate valve to isolate system for maintenance
- Accessory base for optional timer and/or chlorinator

ClearWater II Cartridge Deluxe System with Supreme 2-Speed Pump

Part No.	Filter	Filtration Area	Pump	HP	Volts	Weight (lbs.)	Cord	List (US \$)
FCS075107-3	FC0757	75 sq. ft.	PSP2100-3R	1.0	115	69	3 ft. Twist-Lock	1,356.14
FCS100107-3	FC1007	100 sq. ft.	PSP2100-3R	1.0	115	74	3 ft. Twist-Lock	1,577.88
FCS125157-3	FC1257	125 sq. ft.	PSP2150-3R	1.5	115	--	3 ft. Twist-Lock	1,751.03
FCS150157-3	FC1507	150 sq. ft.	PSP2150-3R	1.5	115	72	3 ft. Twist-Lock	1,884.16
FCS200157-3	FC2007	200 sq. ft.	PSP2150-3R	1.5	115	--	3 ft. Twist-Lock	1,920.93
FCS075107-6	FC0757	75 sq. ft.	PSP2100-6R	1.0	115	69	3 ft. NEMA	1,343.26
FCS100107-6	FC1007	100 sq. ft.	PSP2100-6R	1.0	115	74	3 ft. NEMA	1,601.56
FCS125157-6	FC1257	125 sq. ft.	PSP2150-6R	1.5	115	--	3 ft. NEMA	1,751.42
FCS150157-6	FC1507	150 sq. ft.	PSP2150-6R	1.5	115	72	3 ft. NEMA	1,884.16
FCS200157-6	FC2007	200 sq. ft.	PSP2150-6R	1.5	115	--	3 ft. NEMA	1,920.93

INCLUDES:

- 2 hoses (1 1/2" x 6 ft.)
- Filter/ Pump Union Adapter, hose fittings and hose clamps
- Deluxe one-piece base system
- Unionized gate valve to isolate system for maintenance
- Accessory base for optional timer and/or chlorinator

ClearWater II Cartridge Deluxe System (without Supreme Pump)

Part No.	Filter	Filtration Area	List (US \$)
FCS0757S	FC0757	75 sq. ft.	752.34
FCS1007S	FC1007	100 sq. ft.	1,003.52
FCS1257S	FC1257	125 sq. ft.	1,217.94
FCS1507S	FC1507	150 sq. ft.	1,217.94
FCS2007S	FC2007	200 sq. ft.	1,217.94

All power cords are 3' in length.

Pool Filters - Above Ground / ClearWater II - Cartridge Standard System



FEATURES:

- Large filtration, small footprint cartridge filter
- Hi-Flo II High Performance Single or Dual Speed Pump
- Large 6" pump trap with 2-piece lid
- Two 1 1/2" diameter hoses, with clamps
- Dual speed pump meets CEC Title 20 Code - Effective January 1, 2008



The Cartridge Filter and Pump Pack provides homeowners with everything they need to get their system up and running. It assures them years of dependable service.

ClearWater II Cartridge Standard System with Hi-Flo II 1-Speed Pump

Part No.	Filter	Filtration Area	Pump	HP	Volts	Weight (lbs.)	Cord	List (US \$)
520-5107-3S	FC0757	75 sq. ft.	PH1100-3R	1.0	115	60	3 ft. Twist-Lock	1,085.23
520-5127-3S	FC1007	100 sq. ft.	PH1100-3R	1.0	115	60	3 ft. Twist-Lock	1,262.64
520-5147-3S	FC1007	100 sq. ft.	PH1150-3R	1.5	115	60	3 ft. Twist-Lock	1,270.35
520-5157-3S	FC1257	125 sq. ft.	PH1150-3R	1.5	115	--	3 ft. Twist-Lock	1,357.79
520-5167-3S	FC1507	150 sq. ft.	PH1150-3R	1.5	115	65	3 ft. Twist-Lock	1,445.79
520-5187-3S	FC2007	200 sq. ft.	PH1150-3R	1.5	115	50	3 ft. Twist-Lock	1,575.84
520-5107-6S	FC0757	75 sq. ft.	PH1100-6R	1.0	115	60	3 ft. NEMA	1,085.23
520-5127-6S	FC1007	100 sq. ft.	PH1100-6R	1.0	115	60	3 ft. NEMA	1,262.64
520-5147-6S	FC1007	100 sq. ft.	PH1150-6R	1.5	115	60	3 ft. NEMA	1,270.06
520-5157-6S	FC1257	125 sq. ft.	PH1150-6R	1.5	115	70	3 ft. NEMA	1,273.77
520-5167-6S	FC1507	150 sq. ft.	PH1150-6R	1.5	115	50	3 ft. NEMA	1,445.78
520-5187-6S	FC2007	200 sq. ft.	PH1150-6R	1.5	115	51	3 ft. NEMA	1,585.92

INCLUDES:

- 2 hoses (1 1/2" x 6 ft.)
- Filter / Pump Union Adapter, hose fittings and hose clamps
- 3 ft. cord Twist-Lock plug (NEC/UL), or 3 ft. cord NEMA plug
- One-piece system base

ClearWater II Cartridge Standard System with Hi-Flo II 2-Speed Pump

Part No.	Filter	Filtration Area	Pump	HP	Volts	Weight (lbs.)	Cord	List (US \$)
522-5107-3S	FC0757	75 sq. ft.	PH2100-3R	1.0	115	--	3 ft. Twist-Lock	1,160.24
522-5127-3S	FC1007	100 sq. ft.	PH2100-3R	1.0	115	66	3 ft. Twist-Lock	1,337.66
522-5147-3S	FC1007	100 sq. ft.	PH2150-3R	1.5	115	65	3 ft. Twist-Lock	1,276.73
522-5157-3S	FC1257	125 sq. ft.	PH2150-3R	1.5	115	66	3 ft. Twist-Lock	1,436.88
522-5167-3S	FC1507	150 sq. ft.	PH2150-3R	1.5	115	70	3 ft. Twist-Lock	1,524.93
522-5187-3S	FC2007	200 sq. ft.	PH2150-3R	1.5	115	--	3 ft. Twist-Lock	1,634.18
522-5107-6S	FC0757	75 sq. ft.	PH2100-6R	1.0	115	66	3 ft. NEMA	1,160.24
522-5127-6S	FC1007	100 sq. ft.	PH2100-6R	1.0	115	66	3 ft. NEMA	1,337.65
522-5147-6S	FC1007	100 sq. ft.	PH2150-6R	1.5	115	66	3 ft. NEMA	1,349.46
522-5157-6S	FC1257	125 sq. ft.	PH2150-6R	1.5	115	--	3 ft. NEMA	1,436.88
522-5167-6S	FC1507	150 sq. ft.	PH2150-6R	1.5	115	71	3 ft. NEMA	1,524.93
522-5187-6S	FC2007	200 sq. ft.	PH2150-6R	1.5	115	62	3 ft. NEMA	1,634.56

INCLUDES:

- 2 hoses (1 1/2" x 6 ft.)
- Filter / Pump Union Adapter, hose fittings and hose clamps
- 3 ft. cord Twist-Lock plug (NEC/UL), or 3 ft. cord NEMA plug
- One-piece system base

ClearWater II Cartridge Standard System (without Hi-Flo II Pump)

Part No.	Filter	Filtration Area	Weight (lbs.)	List (US \$)
520-5107	FC0757	75 sq. ft.	--	739.43
520-5127	FC1007	100 sq. ft.	38	849.03
520-5157	FC1257	125 sq. ft.	42	997.15
520-5167	FC1507	150 sq. ft.	43	1,132.05
520-5187	FC2007	200 sq. ft.	43	1,142.69

INCLUDES:

- 2 hoses (1 1/2" x 6 ft.)
- Filter / Pump Union Adapter, hose fittings and hose clamps
- One-piece system base

All power cords are 3' in length.



Pool Filters - In-Ground & Above Ground / ProClean Plus

FEATURES:

- NSF Listed
- 2" FPT inlet and 2" or 2 1/2" S outlets for more flow
- Raised inlet for clean easy plumbing
- Waterway's Safety Lock Ring System for fast, easy access to filter internals
- Lid lock-ring handle makes removing the lid easy and safe
- Internal design for more dirt holding capacity for longer cleaning cycles
- Drain plug is 1"

Designed for in-ground installations, the ProClean Plus Cartridge Filter has a raised inlet for clean easy plumbing from the pump. Molded of ABS thermoplastic, the ProClean Plus Cartridge Filter will provide years of dependable service.



With 1" Threaded Drain Port!

Easy access in-ground cartridge internals
 Raised 18" Inlet for clean 90° plumbing from pump
 Lock-Ring has handles for easy removal of lid

For replacement parts, see page 314.
 For equipment bases, see page 55.

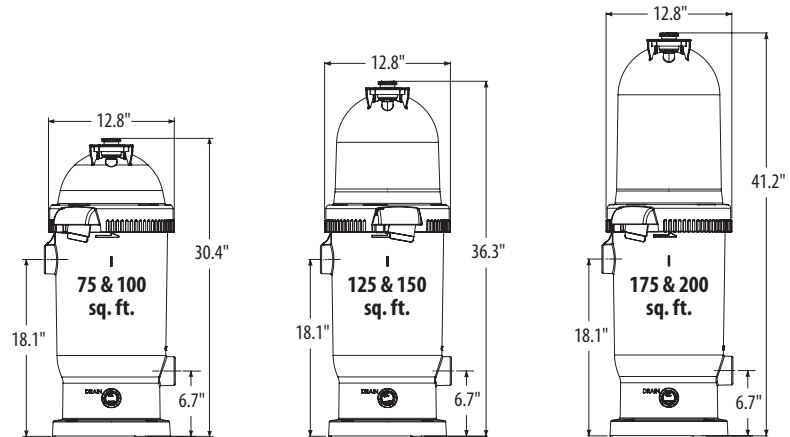

ProClean Plus Single Cartridge Filters

Part No.	Size	Flow Rate	Pool Turnover (6 hrs.)	Pool Turnover (8 hrs.)	Weight (lbs.)	List (US \$)
PCCF-075	75 sq. ft.	75 GPM	27,000	36,000	21	596.57
PCCF-100	100 sq. ft.	100 GPM	36,000	48,000	24	717.56
PCCF-125	125 sq. ft.	125 GPM	45,000	60,000	24	878.28
PCCF-150	150 sq. ft.	125 GPM	45,000	60,000	25	1,019.13
PCCF-175	175 sq. ft.	125 GPM	45,000	60,000	28	1,144.55
PCCF-200*	200 sq. ft.	125 GPM	45,000	60,000	28	1,266.77

*Ideal for longer cleaning cycles



PROPACK

FEATURES:

- 200 sq. ft. cartridge filter with drain plug
- SMF or Champion Pump - Single and Dual Speed Available (not included)
- Equipment pad
- Dual speed pump meets CEC Title 20 Code - Effective January 1, 2008
- Unionized Pump/Filter Sweep connector included



Add an SMF or Champion Pump to complete your ProPack!



Filters / Filter Systems

ProClean Plus Single Cartridge Filter System - ProPack (without SMF or Champion Pump)

Part No.	Description	Weight (lbs.)	List (US \$)
520-7500-0	200 sq. ft. Single Cartridge System with Base and Fittings Package	43	1,482.31

Use with SMF & Champion Pumps:
DO NOT exceed 2 HP for 200 sq ft. Single Cartridge Filter
 See page 16 for SMF or 15 for Champion Pump choices.



Pool Filters - Above Ground / ProClean Plus - Single Cartridge 2-Speed System

FEATURES:

- Raised inlet for clean easy plumbing
- Top-mounted pressure gauge for easy reading
- Extra-large air relief
- Dual speed pump meets CEC Title 20 Code - Effective January 1, 2008



This system is our ProClean Plus in-ground pool filter with Waterway's above ground Hi-Flo II or Supreme Pump for an exceptional above ground system.

ProClean Plus Single Cartridge Systems - Hi-Flo II Pump - 2-Speed

Part No.	Filter	Filtration Area	Pump	HP	Weight (lbs.)	List (US \$)
522-6000-6S	PCCF-075	75 sq. ft.	PH2100-6	1.0	--	1,181.35
522-6100-6S	PCCF-100	100 sq. ft.	PH2100-6	1.0	--	1,335.57
522-6115-6S	PCCF-100	100 sq. ft.	PH2150-6	1.5	--	1,553.90
522-6215-6S	PCCF-125	125 sq. ft.	PH2150-6	1.5	66	1,624.62
522-6315-6S	PCCF-150	150 sq. ft.	PH2150-6	1.5	74	1,695.01
522-6415-6S	PCCF-175	175 sq. ft.	PH2150-6	1.5	--	1,872.77
522-6515-6S	PCCF-200	200 sq. ft.	PH2150-6	1.5	--	1,957.54
522-6520-6S	PCCF-200	200 sq. ft.	PH2200-6	2.0	--	2,121.34

ProClean Plus Single Cartridge Systems - Supreme Pump - 2-Speed

Part No.	Filter	Filtration Area	Pump	HP	Weight (lbs.)	List (US \$)
FPS07510-6	PCCF-075	75 sq. ft.	PSP2100-6	1.0	--	1,292.54
FPS10010-6	PCCF-100	100 sq. ft.	PSP2100-6	1.0	--	1,462.30
FPS10015-6	PCCF-100	100 sq. ft.	PSP2150-6	1.5	--	1,672.43
FPS12515-6	PCCF-125	125 sq. ft.	PSP2150-6	1.5	--	1,748.51
FPS15015-6	PCCF-150	150 sq. ft.	PSP2150-6	1.5	--	1,824.51
FPS17515-6	PCCF-175	175 sq. ft.	PSP2150-6	1.5	--	2,077.01
FPS20015-6	PCCF-200	200 sq. ft.	PSP2150-6	1.5	--	2,171.50
FPS20020-6	PCCF-200	200 sq. ft.	PSP2200-6	2.0	--	2,284.82

Pool Filters - Above Ground / ProClean Plus Single Cartridge 1-Speed System



FEATURES:

- Raised inlet for clean easy plumbing
- Top-mounted pressure gauge for easy reading
- Extra-large air relief



This system is our ProClean Plus in-ground pool filter with Waterway's above ground Hi-Flo II or Supreme Pump for an exceptional above ground system.

Filters / Filter Systems

ProClean Plus Single Cartridge System with Hi-Flo II Pump

Part No.	Filter	Filtration Area	Pump	HP	Weight (lbs.)	List (US \$)
520-6000-6S	PCCF-075	75 sq. ft.	PH1100-6	1.0	--	1,106.33
520-6100-6S	PCCF-100	100 sq. ft.	PH1100-6	1.0	--	1,260.57
520-6115-6S	PCCF-100	100 sq. ft.	PH1150-6	1.5	--	1,475.12
520-6215-6S	PCCF-125	125 sq. ft.	PH1150-6	1.5	--	1,545.50
520-6315-6S	PCCF-150	150 sq. ft.	PH1150-6	1.5	66	1,615.89
520-6415-6S	PCCF-175	175 sq. ft.	PH1150-6	1.5	--	1,810.84
520-6515-6S	PCCF-200	200 sq. ft.	PH1150-6	1.5	--	1,937.14
520-6520-6S	PCCF-200	200 sq. ft.	PH1200-6	2.0	--	2,034.01

ProClean Plus Single Cartridge System with Supreme Pump

Part No.	Filter	Filtration Area	Pump	HP	Weight (lbs.)	List (US \$)
FPS07510-6S	PCCF-075	75 sq. ft.	PSP1100-6	1.0	--	1,217.82
FPS10010-6S	PCCF-100	100 sq. ft.	PSP1100-6	1.0	--	1,387.56
FPS10015-6S	PCCF-100	100 sq. ft.	PSP1150-6	1.5	--	1,593.70
FPS12515-6S	PCCF-125	125 sq. ft.	PSP1150-6	1.5	--	1,669.75
FPS15015-6S	PCCF-150	150 sq. ft.	PSP1150-6	1.5	--	1,745.79
FPS17515-6S	PCCF-175	175 sq. ft.	PSP1150-6	1.5	--	1,956.39
FPS20015-6S	PCCF-200	200 sq. ft.	PSP1150-6	1.5	--	2,112.93
FPS20020-6S	PCCF-200	200 sq. ft.	PSP1200-6	2.0	--	2,197.53



Pool Filters / TWM-30 Series Systems

FEATURES:

- 25 sq. ft. cartridge filter
- 1/8 HP high performance pump with trap
- 3 ft. NEMA cord
- 30 GPM flow rate
- Two 3 ft. x 1 1/2" hoses with connectors
- Equipment pad
- Includes InTex connection fittings



InTex Connection Fittings



TWM-30 Above Ground Cartridge Filter System

Part No.	Description	Flow Rate	Turnover (24 hrs.)	Weight (lbs.)	Cord	List (US \$)
520-4070	25 sq. ft. Filter - 1/8 HP Pump	1800 GPH	43,200 gals.	30	3 ft. NEMA	522.27
520-4070LT	25 sq. ft. Filter - 1/8 HP Pump - without Trap	1800 GPH	43,200 gals.	28	3 ft. NEMA	448.97
400-6437	InTex Connection Fittings	--	--	--	--	24.84

FEATURES:

- 16 in. sand filter
- 1/2 HP high performance pump with trap
- 3 ft. NEMA cord
- Two 6 ft. x 1 1/2" hoses with connectors
- Equipment pad
- Includes InTex connection fittings



InTex Connection Fittings



TWM-30-S Sand Filter System

Part No.	Description	Flow Rate	Turnover (24 hrs.)	Weight (lbs.)	Cord	List (US \$)
520-1601	16in. Filter - 1/2 HP Pump	1800 GPH	43,200 gals.	56	3 ft. NEMA	670.62
520-1601LT	16in. Filter - 1/2 HP Pump - without Trap	1800 GPH	43,200 gals.	56	3 ft. NEMA	581.66



FEATURES:

- 25, 50 or 100 sq. ft. cartridge filter with drain plug
- Center discharge pool pump - Single and Dual Speed
- 3 ft. NEMA (3-prong, grounded) cord, or 3 ft. Twist-Lock cord
- Two 6 ft. x 1 1/2" hoses with connectors
- Equipment pad
- Optional trap: 1 1/2" Union Nut, 1 1/2" FPT
- Dual speed pump meets CEC Title 20 Code - Effective January 1, 2008



For replacement parts, see page 315.

The economical solution for filtering an above ground pool. Waterway's TWM (Total Water Management) package includes the pump, filter, hoses, and equipment pad.

TWM Cartridge Filter Equipment Packages

Part No.	Description	HP	Volts	Weight (lbs.)	Cord	List (US \$)
522-3040	25 sq. ft. Filter - 2-Speed Pump	1.0	115	--	3 ft. NEMA	750.72
522-3010	50 sq. ft. Filter - 2-Speed Pump	1.0	115	40	3 ft. NEMA	857.64
522-3030	100 sq. ft. Filter - 2-Speed Pump	1.0	115	--	3 ft. NEMA	984.22
522-4040	25 sq. ft. Filter - 2-Speed Pump with Trap	1.0	115	--	3 ft. NEMA	904.05
522-4010	50 sq. ft. Filter - 2-Speed Pump with Trap	1.0	115	36	3 ft. NEMA	940.34
522-4030	100 sq. ft. Filter - 2-Speed Pump with Trap	1.0	115	--	3 ft. NEMA	1,066.07
522-2980	25 sq. ft. Filter - 2-Speed Pump	1.0	115	34	3 ft. Twist-Lock	750.57
522-4020	50 sq. ft. Filter - 2-Speed Pump with Trap	1.5	115	36	3 ft. Twist-Lock	786.86
520-3040	25 sq. ft. Filter - 1-Speed Pump	1.0	115	32	3 ft. NEMA	556.28
520-3010	50 sq. ft. Filter - 1-Speed Pump	1.0	115	32	3 ft. NEMA	565.68
520-3030	100 sq. ft. Filter - 1-Speed Pump	1.0	115	32	3 ft. NEMA	619.45
520-4040	25 sq. ft. Filter - 1-Speed Pump with Trap	1.0	115	36	3 ft. NEMA	618.74
520-4010	50 sq. ft. Filter - 1-Speed Pump with Trap	1.0	115	36	3 ft. NEMA	659.18

All power cords are 3' in length.

FEATURES:

- Gate valve action
- 1 1/2" buttress union on one side and 1 1/2" smooth hose on the other
- 3/8" barbed fitting to accommodate offline chlorinators
- Internals are all corrosion-resistant plastics



417-4161



WV001H

Designed to isolate the above-ground pool system to aid in maintenance and service, No-Flo gate-style valves install easily. The valve features a 3/8" barbed fitting to accommodate an offline chlorinator.

No-Flo Gate Valves

Part No.	Description	Case Weight	Case Quantity	List (US \$)
WV001H	Gate Valve with 1 1/2" Union x 1 1/2" Hose Adapter	29	35	32.70
417-4161	Union Tailpiece - 1 1/2" NPT x 1 1/2" (Black)	16	100	5.39
805-0224	O-Ring for 1 1/2" Heater Union Tailpiece (417-4161)	--	100	0.62
711-4000	1 1/2" Union Gasket	6	500	0.64



Pool Filters - In-Ground & Above Ground / Carefree Top-Mount - Sand

FEATURES:

- Large filter with extra sand-holding capacity
- Durable roto-molded oval tank body distributes pressure evenly, resulting in greater strength and longer life of the filter
- One-piece corrosion proof body
- High Flow internal diffuser for even water distribution
- 7- function Top-Mount 1 1/2" FPT Multi-Port Valve with Split-Nut Lock Union (WVS003)
- 1 1/2" drain port
- Mounting base included



For replacement parts, see page 320.
For equipment bases, see page 55.

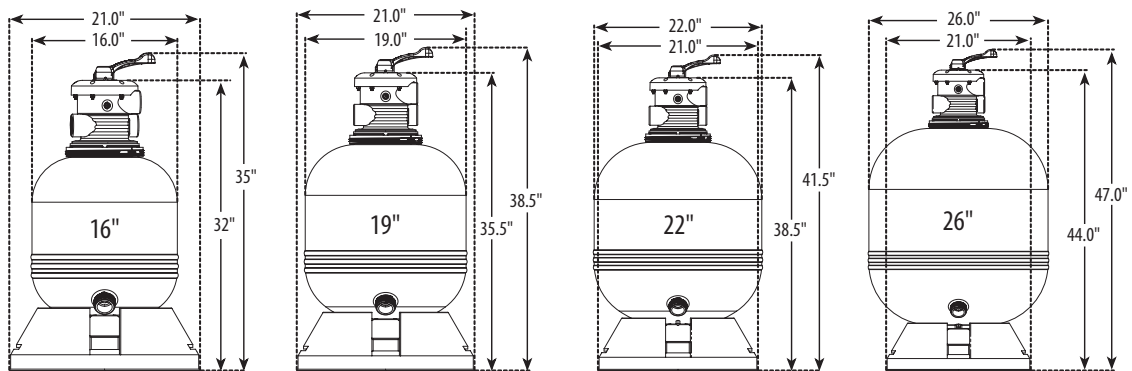

Sand Required

16" - 100 lbs.

19" - 150 lbs.

22" - 250 lbs.

26" - 400 lbs.

Carefree Top-Mount Sand Filters

Part No.	Description	Multi-Port Valve Style	Filtration Area	Flow Rate	Pool Turnover (6-8-10 hrs.)	Weight (lbs.)	List (US \$)
FS016197	16" diameter Filter w/Modular Base	1 1/2" FPT Split-Nut	1.4 sq. ft.	35 GPM	12,600 - 16,800 - 21,000	34	600.97
FS019227	19" diameter Filter w/Modular Base	1 1/2" FPT Split-Nut	2.0 sq. ft.	45 GPM	16,200 - 21,600 - 27,000	43	705.28
FS022257	22" diameter Filter w/Modular Base	1 1/2" FPT Split-Nut	2.6 sq. ft.	55 GPM	19,800 - 26,400 - 33,000	54	835.14
FS026297	26" diameter Filter w/Modular Base	1 1/2" FPT Split-Nut	3.5 sq. ft.	70 GPM	25,200 - 33,600 - 42,000	71	972.72

Carefree Top-Mount Sand Filters are designed for extra sand holding capacity. Made of corrosion-proof polymeric thermoplastic. The Carefree Sand Filter offers the ideal combination of high performance and excellent water clarity. This filter is an excellent choice for above ground or in-ground pools.

Pool Filters - Above Ground / Carefree Top-Mount - Sand Deluxe System



FEATURES:

- Large filter with extra sand-holding capacity
- Top-of-the-line Supreme High Performance Single and Dual Speed Pump
- Extra large 7" pump trap with clear lid
- Union connection on multi-port for easy installation
- Unionized gate valve to isolate the system for maintenance
- Two 1 1/2" diameter hoses with clamps
- Filter and pump mounting bases
- Fittings package for all connections
- Accessory base allows for addition of optional timer and/or Chlorinator kits for minimal maintenance (sold separately)
- Dual speed pump meets CEC Title 20 Code - Effective January 1, 2008

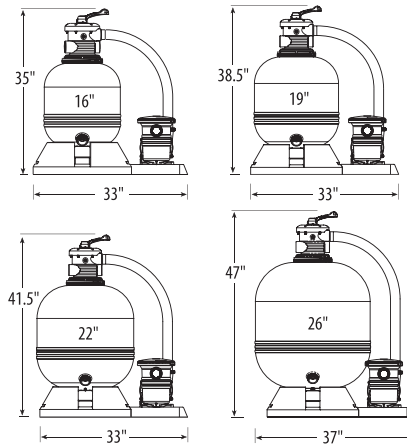

Carefree Sand Filter Systems are designed with the ideal combination of high performance and excellent water clarity. The Carefree Sand Filter and Pump Pack System provides everything needed for an above ground pool package.

Filters / Filter Systems



Carefree Sand Deluxe System with Supreme 1-Speed Pump

Part No.	Filter	Diameter	Filtration Area	Flow Rate	Pump	HP	Weight (lbs.)	Cord	List (US \$)
FSS0169107-3S	FS01619	16"	1.4 sq. ft.	35 GPM	PSP1100-3	1.0	72	3 ft. TL	1,011.47
FSS0199107-3S	FS01922	19"	2.0 sq. ft.	45 GPM	PSP1100-3	1.0	83	3 ft. TL	1,072.94
FSS0229157-3S	FS02225	22"	2.6 sq. ft.	55 GPM	PSP1150-3	1.5	91	3 ft. TL	1,206.43
FSS0269157-3S	FS02629	26"	3.5 sq. ft.	70 GPM	PSP1150-3	1.5	--	3 ft. TL	1,342.37
FSS0169107-6S	FS01619	16"	1.4 sq. ft.	35 GPM	PSP1100-6	1.0	72	3 ft. NEMA	1,011.47
FSS0199107-6S	FS01922	19"	2.0 sq. ft.	45 GPM	PSP1100-6	1.0	83	3 ft. NEMA	1,072.94
FSS0229157-6S	FS02225	22"	2.6 sq. ft.	55 GPM	PSP1150-6	1.5	91	3 ft. NEMA	1,206.43
FSS0269157-6S	FS02629	26"	3.5 sq. ft.	70 GPM	PSP1150-6	1.5	--	3 ft. NEMA	1,343.67

INCLUDES:

- 2 hoses (1 1/2" x 6 ft.)
- Filter / Pump Hose with Union Adapters, hose fittings and hose clamps
- 3 ft. cord Twist-Lock plug (NEC/UL), or 3 ft. cord NEMA plug
- Deluxe modular filter and pump bases
- Unionized gate valve to isolate the system for maintenance

Carefree Sand Deluxe System with Supreme 2-Speed Pump

Part No.	Filter	Diameter	Filtration Area	Flow Rate	Pump	HP	Weight (lbs.)	Cord	List (US \$)
FSS0169107-3	FS01619	16"	1.4 sq. ft.	35 GPM	PSP2100-3	1.0	--	3 ft. TL	1,130.59
FSS0199107-3	FS01922	19"	2.0 sq. ft.	45 GPM	PSP2100-3	1.0	83	3 ft. TL	1,191.67
FSS0229157-3	FS02225	22"	2.6 sq. ft.	55 GPM	PSP2150-3	1.5	91	3 ft. TL	1,360.93
FSS0269157-3	FS02629	26"	3.5 sq. ft.	70 GPM	PSP2150-3	1.5	--	3 ft. TL	1,484.87
FSS0169107-6	FS01619	16"	1.4 sq. ft.	35 GPM	PSP2100-6	1.0	--	3 ft. NEMA	1,130.58
FSS0199107-6	FS01922	19"	2.0 sq. ft.	45 GPM	PSP2100-6	1.0	83	3 ft. NEMA	1,191.66
FSS0229157-6	FS02225	22"	2.6 sq. ft.	55 GPM	PSP2150-6	1.5	91	3 ft. NEMA	1,360.93
FSS0269157-6	FS02629	26"	3.5 sq. ft.	70 GPM	PSP2150-6	1.5	--	3 ft. NEMA	1,484.88

INCLUDES:

- 2 hoses (1 1/2" x 6 ft.)
- Filter / Pump Hose with Union Adapters, hose fittings and hose clamps
- 3 ft. cord Twist-Lock plug (NEC/UL), or 3 ft. cord NEMA plug
- Deluxe modular filter and pump bases
- Unionized gate valve to isolate the system for maintenance

Carefree Sand Deluxe System (without Supreme Pump)

Part No.	Filter	Diameter	Filtration Area	Flow Rate	Weight (lbs.)	List (US \$)
FSS0169S7	FS01619	16"	1.4 sq. ft.	35 GPM	--	564.51
FSS0199S7	FS01922	19"	2.0 sq. ft.	45 GPM	--	653.87
FSS0229S7	FS02225	22"	2.6 sq. ft.	55 GPM	--	836.42
FSS0269S7	FS02629	26"	3.5 sq. ft.	70 GPM	--	1,034.43

INCLUDES:

- 2 hoses (1 1/2" x 6 ft.)
- Filter / Pump Hose with Union Adapters, hose fittings and hose clamps
- Deluxe modular filter and pump bases
- Unionized gate valve to isolate the system for maintenance

All power cords are 3' in length.



Pool Filters - Above Ground / Carefree Top-Mount - Sand Standard System

FEATURES:

- Large filter with extra sand-holding capacity
- Hi-Flo II High Performance Single and Dual Speed Pump
- Large 6" pump trap with 2-piece lid
- Standard pump and filter base
- Fittings package for all connections
- Dual speed pump meets CEC Title 20 Code - Effective January 1, 2008

Carefree Sand Filter Systems are designed with the ideal combination of high performance and excellent water clarity. The Carefree Sand Filter and Pump Pack System provides everything needed for an above ground pool package.



INCLUDES:

- 2 hoses (1 1/2" x 6 ft.)
- Filter / Pump Hose with Union Adapters, hose fittings and hose clamps
- 3 ft. cord Twist-Lock plug (NEC/UL), or 3 ft. cord NEMA plug
- Standard system base

Carefree Sand Standard System with Hi-Flo II 1-Speed Pump

Part No.	Filter	Diameter	Filtration Area	Flow Rate	Pump	HP	Weight (lbs.)	Cord	List (US \$)
520-5300-3S	FS01619	16"	1.4 sq. ft.	35 GPM	PH1100-3	1.0	65	3 ft. TL	928.55
520-5320-3S	FS01922	19"	2.0 sq. ft.	45 GPM	PH1100-3	1.0	74	3 ft. TL	989.99
520-5330-3S	FS01922	19"	2.0 sq. ft.	45 GPM	PH1150-3	1.5	--	3 ft. TL	1,012.25
520-5350-3S	FS02225	22"	2.6 sq. ft.	55 GPM	PH1100-3	1.0	80	3 ft. TL	1,014.10
520-5340-3S	FS02225	22"	2.6 sq. ft.	55 GPM	PH1150-3	1.5	80	3 ft. TL	1,158.60
520-5300-6S	FS01619	16"	1.4 sq. ft.	35 GPM	PH1100-6	1.0	61	3 ft. NEMA	928.55
520-5320-6S	FS01922	19"	2.0 sq. ft.	45 GPM	PH1100-6	1.0	74	3 ft. NEMA	989.99
520-5330-6S	FS01922	19"	2.0 sq. ft.	45 GPM	PH1150-6	1.5	74	3 ft. NEMA	1,012.25
520-5350-6S	FS02225	22"	2.6 sq. ft.	55 GPM	PH1100-6	1.0	80	3 ft. NEMA	1,014.10
520-5340-6S	FS02225	22"	2.6 sq. ft.	55 GPM	PH1150-6	1.5	80	3 ft. NEMA	1,158.60
520-5360-6S	FS02629	26"	3.5 sq. ft.	70 GPM	PH1150-6	1.5	103	3 ft. NEMA	1,360.74

INCLUDES:

- 2 hoses (1 1/2" x 6 ft.)
- Filter / Pump Hose with Union Adapters, hose fittings and hose clamps
- 3 ft. cord Twist-Lock plug (NEC/UL), or 3 ft. cord NEMA plug
- Standard system base

Carefree Sand Standard System with Hi-Flo II 2-Speed Pump

Part No.	Filter	Diameter	Filtration Area	Flow Rate	Pump	HP	Weight (lbs.)	Cord	List (US \$)
522-5300-3S	FS01619	16"	1.4 sq. ft.	35 GPM	PH2100-3	1.0	--	3 ft. TL	1,050.99
522-5320-3S	FS01922	19"	2.0 sq. ft.	45 GPM	PH2100-3	1.0	--	3 ft. TL	1,118.73
522-5330-3S	FS01922	19"	2.0 sq. ft.	45 GPM	PH2150-3	1.5	--	3 ft. TL	1,130.40
522-5350-3S	FS02225	22"	2.6 sq. ft.	55 GPM	PH2100-3	1.0	87	3 ft. TL	1,240.43
522-5340-3S	FS02225	22"	2.6 sq. ft.	55 GPM	PH2150-3	1.5	--	3 ft. TL	1,276.73
522-5300-6S	FS01619	16"	1.4 sq. ft.	35 GPM	PH2100-6	1.0	66	3 ft. NEMA	1,056.70
522-5320-6S	FS01922	19"	2.0 sq. ft.	45 GPM	PH2100-6	1.0	75	3 ft. NEMA	1,120.85
522-5330-6S	FS01922	19"	2.0 sq. ft.	45 GPM	PH2150-6	1.5	74	3 ft. NEMA	1,130.40
522-5350-6S	FS02225	22"	2.6 sq. ft.	55 GPM	PH2100-6	1.0	87	3 ft. NEMA	1,240.43
522-5340-6S	FS02225	22"	2.6 sq. ft.	55 GPM	PH2150-6	1.5	87	3 ft. NEMA	1,276.73



FEATURES:

- Durable roto-molded tank body is spherical to evenly distribute pressure, resulting in greater strength and longer life of the filter
- Corrosion-proof body
- High Flow internal diffuser for even water distribution
- 7-function Top-Mount 1 1/2" FPT Multi-Port Valve with Split-Nut Lock Union
- 1 1/2" drain port
- Mounting base included

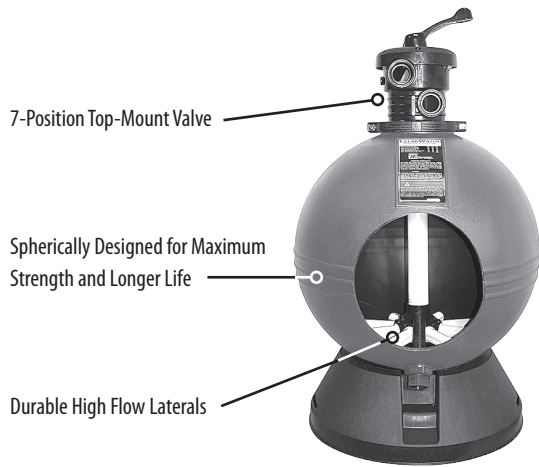

Rugged, corrosion proof, high filtration area, and one-piece body. The ClearWater Sand filter features a seven-function top mount valve for maximum control over the filter system, and full flow, self cleaning laterals with large surface area for maximum flow. This filter is an excellent choice for above ground or in-ground pools.

*For replacement parts, see page 322.
For equipment bases, see page 55.*

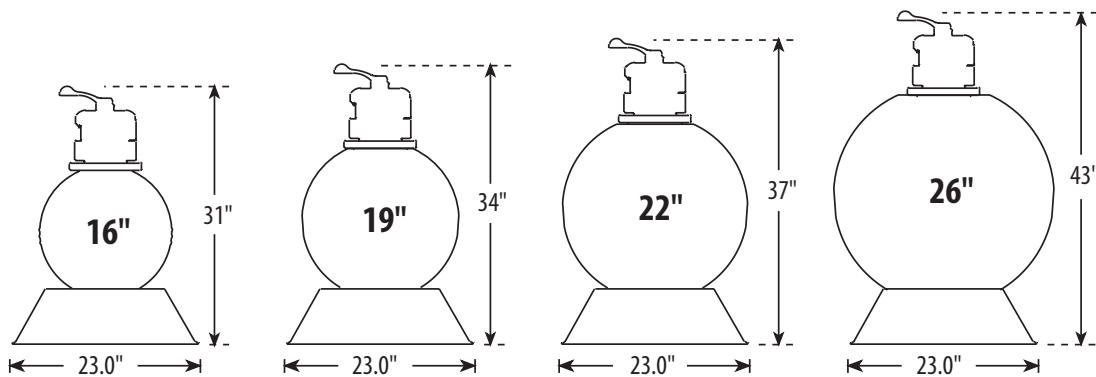

Sand Required

16" - 50 lbs.

19" - 100 lbs.

22" - 150 lbs.

26" - 200 lbs.

ClearWater Sand Filter

Part No.	Description	Filtration Area	Flow Rate	Pool Turnover (6 hrs.)	Pool Turnover (8 hrs.)	Weight (lbs.)	List (US \$)
FS016	16" diameter Filter	1.4 sq. ft.	35 GPM	12,600	16,800	25	498.97
FS019	19" diameter Filter	2.0 sq. ft.	45 GPM	16,200	21,600	28	652.51
FS022	22" diameter Filter	2.6 sq. ft.	55 GPM	19,800	26,400	34	755.54
FS026	26" diameter Filter	3.5 sq. ft.	70 GPM	25,200	33,600	43	875.74

1 1/2" FPT split-nut style clamp included.



Pool Filters - Above Ground / **ClearWater - Sand Deluxe 2-Speed System**

FEATURES:

- Large filtration sand filter with durable, high flow laterals
- Top-of-the-Line Supreme High Performance Dual Speed Pump
- Extra large 7" pump trap with clear lid
- Union connection on multi-port for easy installation
- Unionized gate valve to isolate the system for maintenance
- Two 1 1/2" diameter hoses with clamps
- Filter and pump mounting base
- Fittings package for all connections
- Accessory base allows for addition of optional timer and/or chlorinator kits for minimal maintenance (sold separately)
- Dual speed pump meets CEC Title 20 Code - Effective January 1, 2008



Complete the Sand filtration system with the high performance Waterway Supreme Pump and accessories. The Sand Filter and Pump Pack provides homeowners with everything they need to get their system up and running. It assures them of matched components and optimal performance with years of dependable service.

INCLUDES:

- 2 hoses (1 1/2" x 6 ft.)
- Filter / Pump Hose with Union Adapters, hose fittings and hose clamps
- 3 ft. cord Twist-Lock plug (NEC/UL), or 3 ft. cord NEMA plug
- Deluxe modular filter and pump base
- Unionized gate valve to isolate the system for maintenance
- Accessory base for optional timer and/or chlorinator

INCLUDES:

- 2 hoses (1 1/2" x 6 ft.)
- Filter / Pump Hose with Union Adapters, hose fittings and hose clamps
- Deluxe modular filter and pump base
- Unionized gate valve to isolate the system for maintenance
- Accessory base for optional timer and/or chlorinator

ClearWater Sand Deluxe System with Supreme 2-Speed Pump

Part No.	Filter	Diameter	Filtration Area	Flow Rate	Pump	HP	Weight (lbs.)	Cord	List (US \$)
FSS01910-3	FS019	19"	2.0 sq. ft.	45 GPM	PSP2100-3	1.0	61	3 ft. Twist-Lock	1,301.10
FSS01915-3	FS019	19"	2.0 sq. ft.	45 GPM	PSP2150-3	1.5	64	3 ft. Twist-Lock	1,148.98
FSS02210-3	FS022	22"	2.6 sq. ft.	55 GPM	PSP2100-3	1.0	67	3 ft. Twist-Lock	1,438.20
FSS02215-3	FS022	22"	2.6 sq. ft.	55 GPM	PSP2150-3	1.5	70	3 ft. Twist-Lock	1,449.07
FSS02615-3	FS026	26"	3.5 sq. ft.	70 GPM	PSP2150-3	1.5	77	3 ft. Twist-Lock	1,568.98
FSS01910-6	FS019	19"	2.0 sq. ft.	45 GPM	PSP2100-6	1.0	60	3 ft. NEMA	1,301.10
FSS01915-6	FS019	19"	2.0 sq. ft.	45 GPM	PSP2150-6	1.5	63	3 ft. NEMA	1,420.80
FSS02210-6	FS022	22"	2.6 sq. ft.	55 GPM	PSP2100-6	1.0	67	3 ft. NEMA	1,438.20
FSS02215-6	FS022	22"	2.6 sq. ft.	55 GPM	PSP2150-6	1.5	74	3 ft. NEMA	1,262.46
FSS02615-6	FS026	26"	3.5 sq. ft.	70 GPM	PSP2150-6	1.5	--	3 ft. NEMA	1,568.98

ClearWater Sand Deluxe System (without Supreme Pump)

Part No.	Filter	Diameter	Filtration Area	Flow Rate	Weight (lbs.)	List (US \$)
FSS019S	FS019	19"	2.0 sq. ft.	45 GPM	38	735.73
FSS022S	FS022	22"	2.6 sq. ft.	55 GPM	37	841.88
FSS026S	FS026	26"	3.5 sq. ft.	70 GPM	68	970.63

All power cords are 3' in length.

Pool Filters - Above Ground / ClearWater - Sand Deluxe 1-Speed System



FEATURES:

- Large filtration sand filter with durable, high flow laterals
- Top-of-the-Line Supreme High Performance Pump
- Extra large 7" pump trap with clear lid
- Union connection on multi-port for easy installation
- Unionized gate valve to isolate the system for maintenance
- Two 1 1/2" diameter hoses with clamps
- Filter and pump mounting bases
- Fittings package for all connections
- Accessory base allows for addition of optional timer and/or Chlorinator kits for minimal maintenance (sold separately)



Complete the Sand filtration system with the high performance Waterway Supreme Pump and accessories. The Sand Filter and Pump Pack provides homeowners with everything they need to get their system up and running. It assures them of matched components and optimal performance with years of dependable service.

Filters / Filter Systems

ClearWater Sand Deluxe System with Supreme 1-Speed Pump

Part No.	Filter	Diameter	Filtration Area	Flow Rate	Pump	HP	Weight (lbs.)	Cord	List (US \$)
FSS01910-3S	FS019	19"	2.0 sq. ft.	45 GPM	PSP1100-3	1.0	60	3 ft. Twist-Lock	979.65
FSS01915-3S	FS019	19"	2.0 sq. ft.	45 GPM	PSP1150-3	1.5	64	3 ft. Twist-Lock	1,029.61
FSS02210-3S	FS022	22"	2.6 sq. ft.	55 GPM	PSP1100-3	1.0	67	3 ft. Twist-Lock	1,229.67
FSS02215-3S	FS022	22"	2.6 sq. ft.	55 GPM	PSP1150-3	1.5	70	3 ft. Twist-Lock	1,107.97
FSS02615-3S	FS026	26"	3.5 sq. ft.	70 GPM	PSP1150-3	1.5	77	3 ft. Twist-Lock	1,234.87
FSS01910-6S	FS019	19"	2.0 sq. ft.	45 GPM	PSP1100-6	1.0	60	3 ft. NEMA	979.65
FSS01915-6S	FS019	19"	2.0 sq. ft.	45 GPM	PSP1150-6	1.5	63	3 ft. NEMA	1,255.19
FSS02210-6S	FS022	22"	2.6 sq. ft.	55 GPM	PSP1100-6	1.0	66	3 ft. NEMA	1,058.02
FSS02215-6S	FS022	22"	2.6 sq. ft.	55 GPM	PSP1150-6	1.5	68	3 ft. NEMA	1,107.97
FSS02615-6S	FS026	26"	3.5 sq. ft.	70 GPM	PSP1150-6	1.5	77	3 ft. NEMA	1,413.46

INCLUDES:

- 2 hoses (1 1/2" x 6 ft.)
- Filter / Pump Hose with Union Adapters, hose fittings and hose clamps
- 3 ft. cord Twist-Lock plug (NEC/UL), or 3 ft. cord NEMA plug
- Deluxe modular filter and pump base
- Unionized gate valve to isolate the system for maintenance

ClearWater Sand Deluxe System (without Supreme Pump)

Part No.	Filter	Diameter	Filtration Area	Flow Rate	Weight (lbs.)	List (US \$)
FSS019S	FS019	19"	2.0 sq. ft.	45 GPM	38	735.73
FSS022S	FS022	22"	2.6 sq. ft.	55 GPM	37	841.88
FSS026S	FS026	26"	3.5 sq. ft.	70 GPM	68	970.63

INCLUDES:

- 2 hoses (1 1/2" x 6 ft.)
- Filter / Pump Hose with Union Adapters, hose fittings and hose clamps
- Deluxe modular filter and pump base
- Unionized gate valve to isolate the system for maintenance

All power cords are 3' in length.



Pool Filters - Above Ground / ClearWater - Sand Standard System

Complete the Sand filtration system with the high performance Waterway Hi-Flo II Pump and accessories. The Sand Filter and Pump Pack provides homeowners with everything they need to get their system up and running. It assures them of matched components and optimal performance with years of dependable service.

FEATURES:

- Large filtration sand filter with durable, high flow laterals
- Hi-Flo II High Performance Single and Dual Speed Pump
- Large 6" pump trap with 2-piece lid
- Union connection on multi-port for easy installation
- Two 1 1/2" diameter hoses with clamps
- Dual speed pump meets CEC Title 20 Code - Effective January 1, 2008



INCLUDES:

- 2 hoses (1 1/2" x 6 ft.)
- Filter / Pump Hose with Union Adapters, hose fittings and hose clamps
- 3 ft. cord Twist-Lock plug (NEC/UL), or 3 ft. cord NEMA plug
- Standard system base

ClearWater Sand Standard System with Hi-Flo II 1-Speed Pump

Part No.	Filter	Diameter	Filtration Area	Flow Rate	Pump	HP	Weight (lbs.)	Cord	List (US \$)
520-5200-3S	FS016	16"	1.4 sq. ft.	35 GPM	PH1100-3	1.0	59	3 ft. TL	857.23
520-5220-3S	FS019	19"	2.0 sq. ft.	45 GPM	PH1100-3	1.0	67	3 ft. TL	896.73
520-5240-3S	FS022	22"	2.6 sq. ft.	55 GPM	PH1150-3	1.5	71	3 ft. TL	1,060.15
520-5260-3S	FS026	26"	3.5 sq. ft.	70 GPM	PH1150-3	1.5	83	3 ft. TL	1,151.91
520-5200-6S	FS016	16"	1.4 sq. ft.	35 GPM	PH1100-6	1.0	59	3 ft. NEMA	857.23
520-5220-6S	FS019	19"	2.0 sq. ft.	45 GPM	PH1100-6	1.0	64	3 ft. NEMA	896.73
520-5240-6S	FS022	22"	2.6 sq. ft.	55 GPM	PH1150-6	1.5	68	3 ft. NEMA	1,060.15
520-5260-6S	FS026	26"	3.5 sq. ft.	70 GPM	PH1150-6	1.5	77	3 ft. NEMA	1,151.91

INCLUDES:

- 2 hoses (1 1/2" x 6 ft.)
- Filter / Pump Hose with Union Adapters, hose fittings and hose clamps
- 3 ft. cord Twist-Lock plug (NEC/UL), or 3 ft. cord NEMA plug
- Standard system base

ClearWater Sand Standard System with Hi-Flo II 2-Speed Pump

Part No.	Filter	Diameter	Filtration Area	Flow Rate	Pump	HP	Weight (lbs.)	Cord	List (US \$)
522-5200-3S	FS016	16"	1.4 sq. ft.	35 GPM	PH2100-3	1.0	--	3 ft. TL	975.36
522-5220-3S	FS019	19"	2.0 sq. ft.	45 GPM	PH2100-3	1.0	--	3 ft. TL	1,014.86
522-5240-3S	FS022	22"	2.6 sq. ft.	55 GPM	PH2150-3	1.5	73	3 ft. TL	1,178.23
522-5260-3S	FS026	26"	3.5 sq. ft.	70 GPM	PH2150-3	1.5	--	3 ft. TL	1,408.34
522-5200-6S	FS016	16"	1.4 sq. ft.	35 GPM	PH2100-6	1.0	68	3 ft. NEMA	975.36
522-5220-6S	FS019	19"	2.0 sq. ft.	45 GPM	PH2100-6	1.0	69	3 ft. NEMA	1,014.86
522-5240-6S	FS022	22"	2.6 sq. ft.	55 GPM	PH2150-6	1.5	74	3 ft. NEMA	1,180.73
522-5260-6S	FS026	26"	3.5 sq. ft.	70 GPM	PH2150-6	1.5	87	3 ft. NEMA	1,408.34

INCLUDES:

- 2 hoses (1 1/2" x 6 ft.)
- Filter / Pump Hose with Union Adapters, hose fittings and hose clamps
- Standard system base

ClearWater Sand Standard System (without Hi-Flo II Pump)

Part No.	Filter	Diameter	Filtration Area	Flow Rate	Weight (lbs.)	List (US \$)
520-5200	FS016	16"	1.4 sq. ft.	35 GPM	34	618.50
520-5220	FS019	19"	2.0 sq. ft.	45 GPM	35	703.39
520-5240	FS022	22"	2.6 sq. ft.	55 GPM	40	793.29
520-5260	FS026	26"	3.5 sq. ft.	70 GPM	--	938.71

Pool Filters - Above Ground / TWM Sand Filter Equipment Packages



FEATURES:

- Filter, pump, hoses and fittings in one box
- Choice of tank and pump sizes
- Spherical tank design evenly distributes pressure and stress resulting in greater strength and longer life
- Corrosion-proof sand filter tank
- 7 position Multi-Port Valve
- Center discharge pump with leaf trap - Single and Dual Speed
- Dual speed pump meets CEC Title 20 Code - Effective January 1, 2008

The economical solution for filtering with a sand filter on an above ground pool. Designed to handle virtually all sizes and conditions, the Waterway TWM Sand Filter systems will provide years of dependable filtration.



For replacement parts, see page 324.

TWM Sand Filter Equipment Packages - 1-Speed

Part No.	Description	Filtration	Flow Rate	Turnover (8 - 10 hrs.)	Sand (lbs.)	Cord	List (US \$)
520-1610	16" Sand Filter - 1 HP Center Discharge Pump	1.4 sq. ft.	30 GPM	14,400 - 18,000	50	3 ft. NEMA	788.01
520-1910	19" Sand Filter - 1 HP Center Discharge Pump	2.0 sq. ft.	42 GPM	20,160 - 25,200	100	3 ft. NEMA	829.85
520-1700	22" Sand Filter - 1.5 HP Center Discharge Pump	2.5 sq. ft.	50 GPM	24,000 - 30,000	150	3 ft. NEMA	894.27
520-1610-3	16" Sand Filter - 1 HP Center Discharge Pump	1.4 sq. ft.	30 GPM	14,400 - 18,000	50	3 ft. Twist-Lock	788.01
520-1910-3	19" Sand Filter - 1 HP Center Discharge Pump	2.0 sq. ft.	42 GPM	20,160 - 25,200	100	3 ft. Twist-Lock	829.84
520-1700-3	22" Sand Filter - 1.5 HP Center Discharge Pump	2.5 sq. ft.	50 GPM	24,000 - 30,000	150	3 ft. Twist-Lock	894.27

TWM Sand Filter Equipment Packages - 2-Speed

Part No.	Description	Filtration	Flow Rate	Turnover (8 - 10 hrs.)	Sand (lbs.)	Cord	List (US \$)
522-1610	16" Sand Filter - 1 HP Center Discharge Pump	1.4 sq. ft.	30 GPM	14,400 - 18,000	50	3 ft. NEMA	914.82
522-1910	19" Sand Filter - 1 HP Center Discharge Pump	2.0 sq. ft.	42 GPM	20,160 - 25,200	100	3 ft. NEMA	947.96
522-1700	22" Sand Filter - 1.5 HP Center Discharge Pump	2.5 sq. ft.	50 GPM	24,000 - 30,000	150	3 ft. NEMA	1,003.75
522-1610-3	16" Sand Filter - 1 HP Center Discharge Pump	1.4 sq. ft.	30 GPM	14,400 - 18,000	50	3 ft. Twist-Lock	914.82
522-1910-3	19" Sand Filter - 1 HP Center Discharge Pump	2.0 sq. ft.	42 GPM	20,160 - 25,200	100	3 ft. Twist-Lock	947.96
522-1700-3	22" Sand Filter - 1.5 HP Center Discharge Pump	2.5 sq. ft.	50 GPM	24,000 - 30,000	150	3 ft. Twist-Lock	1,003.75